

Kayt Village



A symbol for Community¹

—
Kayt Village is an intelligent furniture collection that promotes dynamic work environments. Offering employees the freedom to seek out the optimal environment for the task at hand, each piece plays a part in creating a unique community for its people.

schiaavello



Introducing Kayt Village

Blur the lines of furniture & architecture

Kayt Village is solid yet striking. The angular forms add definition and structure to a room, allowing for easy implementation and flexible space reconfiguration into space planning without interfering with the building's structure.

Kayt Nook and Kayt Hutch are space efficient solutions that can 'activate' small spaces or otherwise unutilised transitional spaces. Creating both semi enclosed areas in open workspaces, Kayt Village enables balanced and active working environments.



Spaces for diversity, empowering people

Kayt Village falls into three categories: Cabana creates areas for communication, Nook provides places to retreat for concentrated work and Hutch can be configured for both meeting and individual working settings.

Every worker has a different preference for when and how to concentrate. Kayt Nook and Kayt Hutch help creative workers focus to generate innovative ideas.



Acoustic cocoon, enhanced connectivity

Proving a place for easy communication or retreat and relaxation, Kayt Village's room within a room enables privacy. Responding to the necessity for noise reduction in open plan spaces, Kayt Village helps to absorb disruptive sounds in the surrounding environment.

Without sending participants behind closed doors, Kayt Cabana can spontaneously serve as a meeting space, video conference room, telephone booth, reading corner or quiet spot for a coffee break. Featuring full multi-media facilities and integral, programmable lighting, Kayt Cabana is ideal for connecting people.



Complementary furniture – Tables

From a choice of a 4-Star base or T-leg, Krossi tables form a basis for productive discussions. Featuring a unique top that allows for easy entry and exit into Kayt Cabana, the Krossi tables are available in a variety of laminates, veneers and powder coats from the ColourLab range.

Krossi 4-star base



Krossi T-Leg



Table top



Covering — Leather

Aniline dyed, fully pigmented with an embossed natural pebble grain, the Schiavello leather meets high quality and function. Creating a uniform and elegant appearance, the Schiavello leather is well suited to the contract sector.

Schiavello Leather



Fabric

The Blazer range is a robust and beautifully soft woven upholstery fabric with a compacted felted finish. Made of 100% Laneve wool, the Blazer range is sustainably produced and renewable. Easy to care for and durable, the Blazer is highly abrasive resistant and well suited to the contract sector.

Camira Blazer

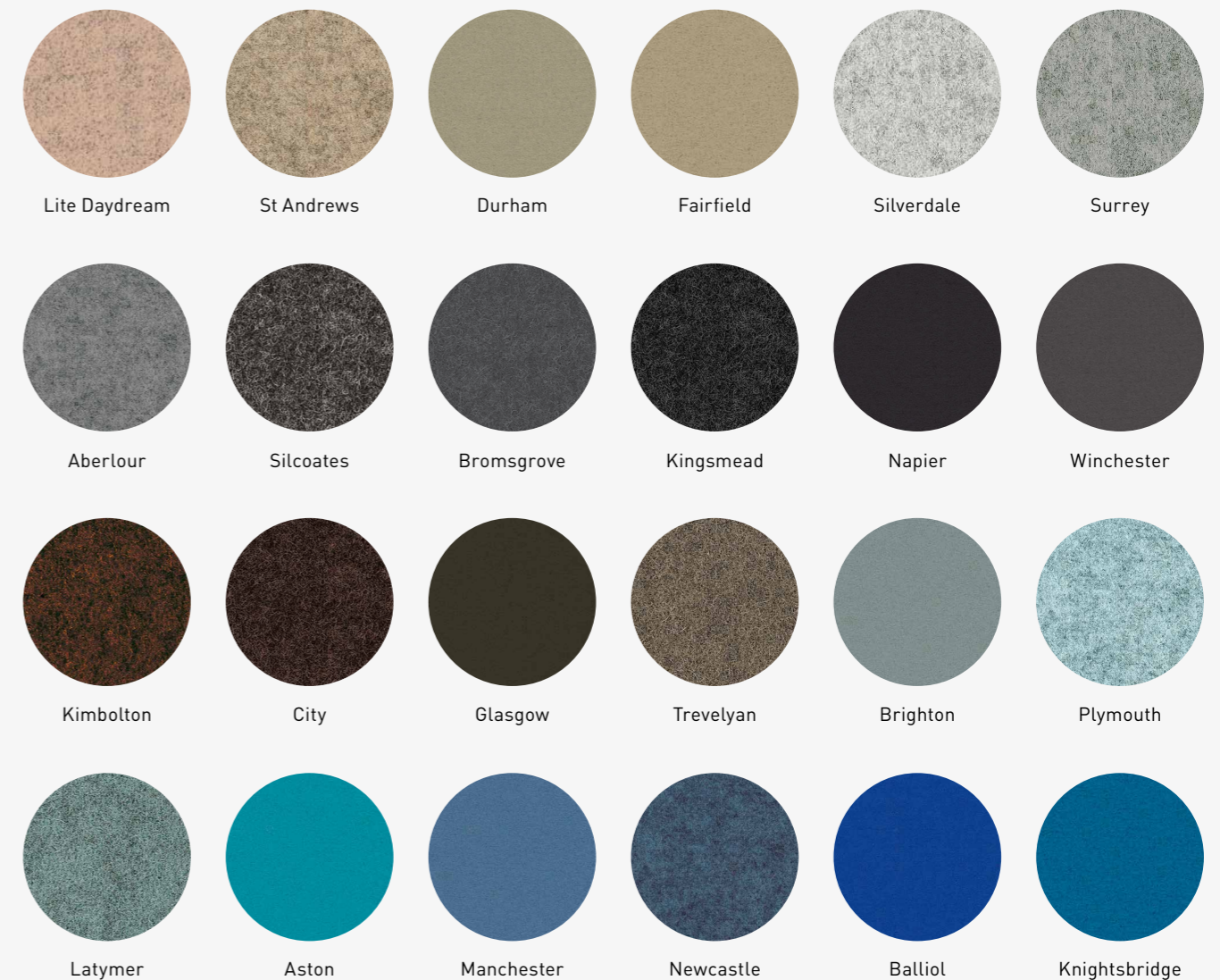

Camira Blazer

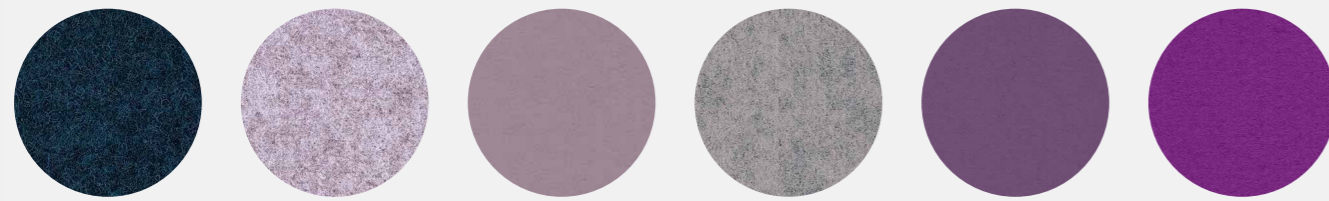

Glenalmond Nottingham Sheffield Salford Exeter Eastbourne

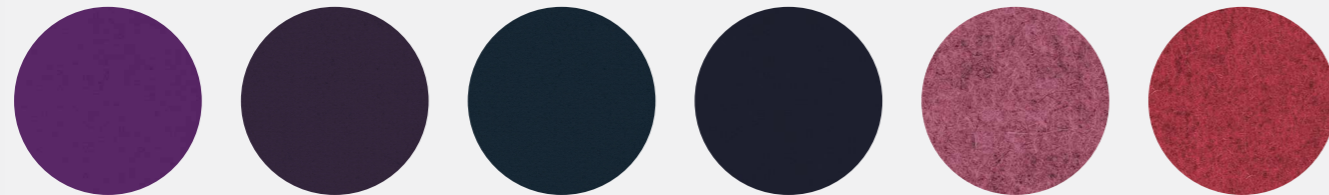

Loughborough Collingwood Edinburgh Oxford St Martins Aberdeen



Sussex Rockport Magdalene Imperial Bambridge Handcross

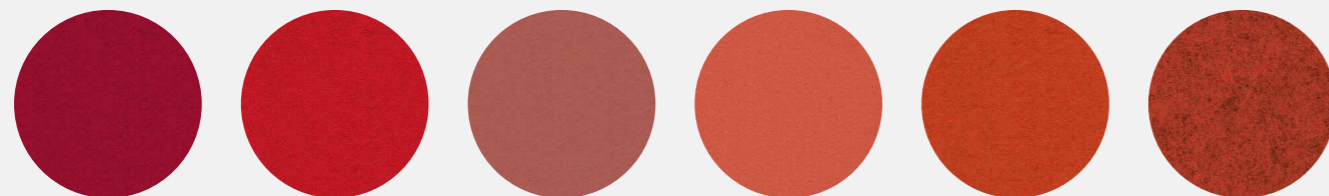

Wellington Oriel Dollar Keil Goldsmith Edgehill

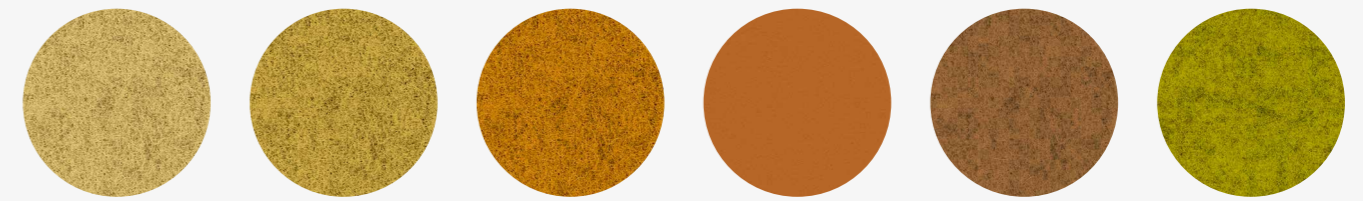

Bath Dunhurst Wesley Butterstone Starley Ulster

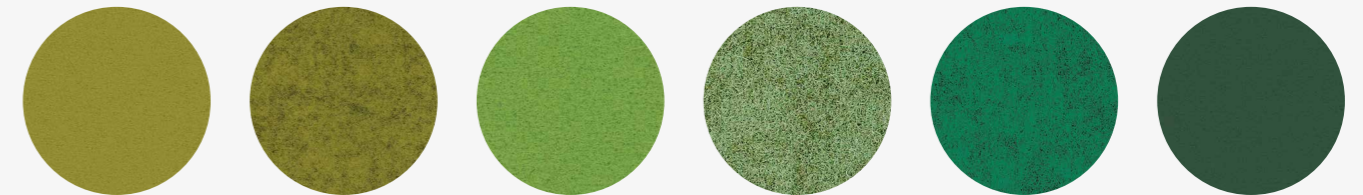

Bryanston Camphill Newport Lancaster Belhaven Cardiff



Hull

ColourLab Finishes — Worktops

Designed for contemporary, commercial and living environments, the ColourLab Palette was developed by Giulio Ridolfo. The perception of light was a strong theme that influenced this considered palette of families of colour, encircling the purity of morning light, natural light, watercolours and winter sunset.

Veneers

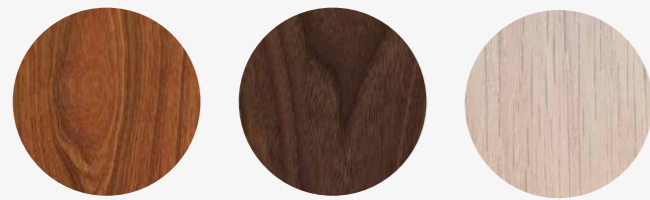

Natural American Cherry

American Black Walnut

Limewood

Stains

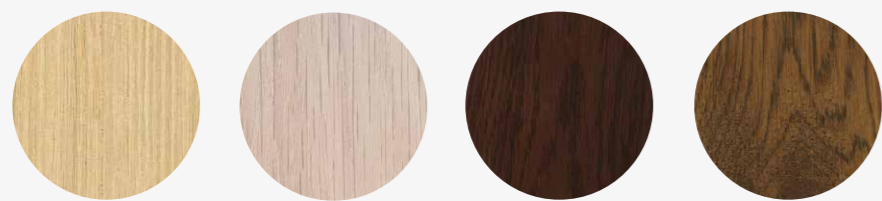

Natural American Oak

Limewood

Walnut Milano

Walnut Bianco

Washes



Shine

Terra

Lipstick

Spring

Blush

Glacier



Satin

Lilac

Mudbrick

Strata

Dorian

Laminates

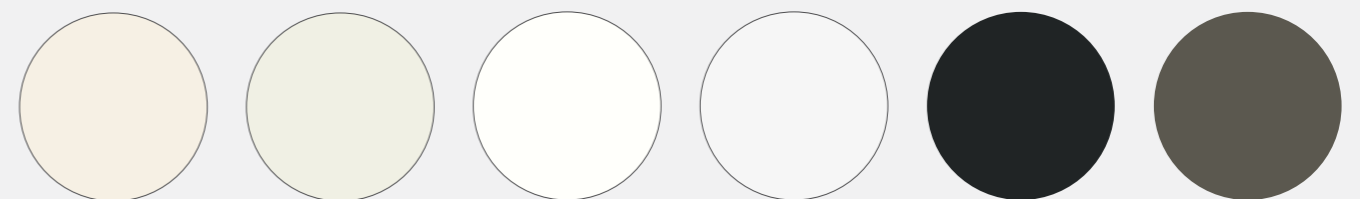

Parchment

Ash White

White

Polar White

Black

Fossil

Legs

MDF powder coat

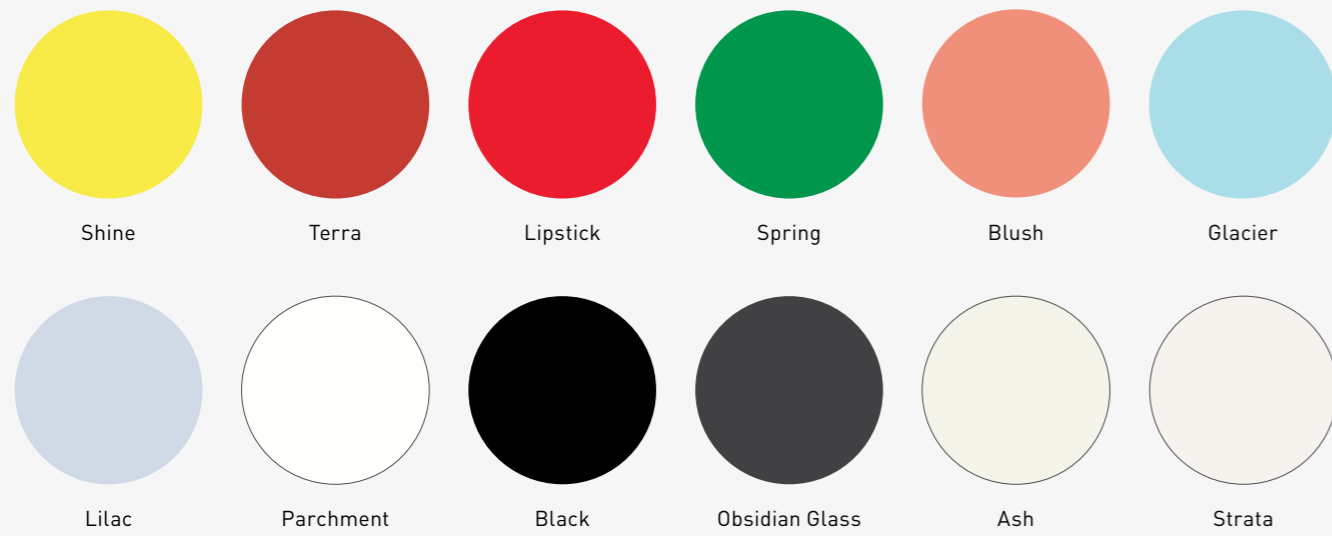

Metal powder coat



Measurements — Kayt Cabana

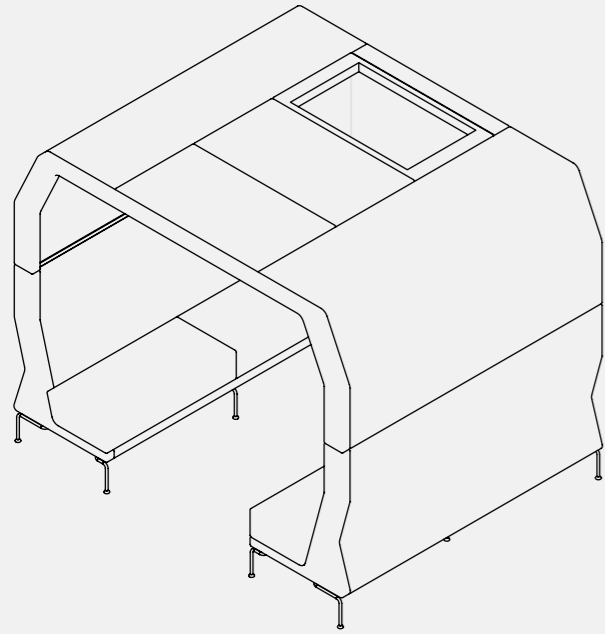

Front

Side

Top

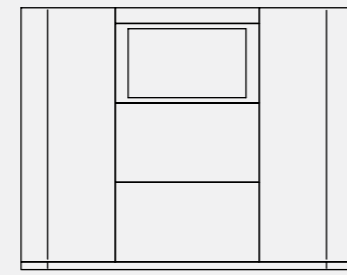
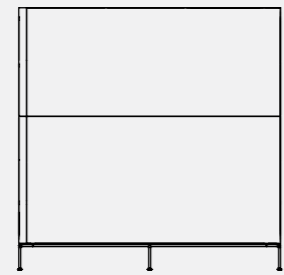
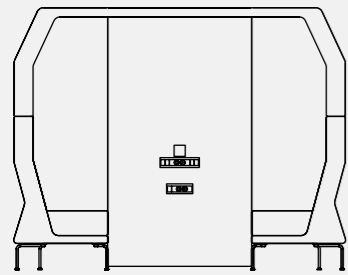

2530

2000

2000

2000

2530

2000

Kayt Hutch

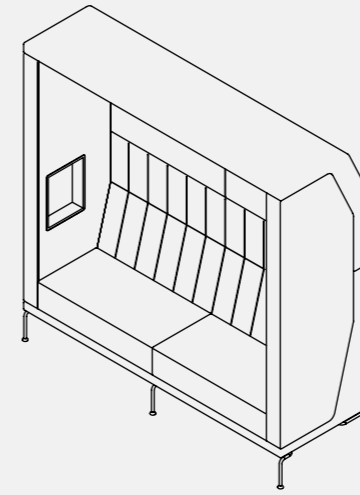

Front

Side

Top

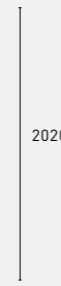
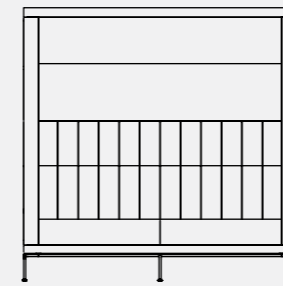

2020

2020

725

2020

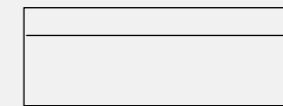

725

2020

Kayt Nook

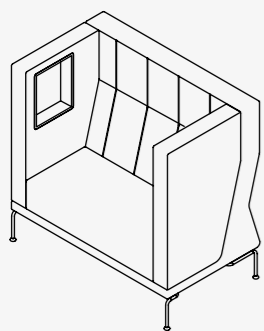

Front

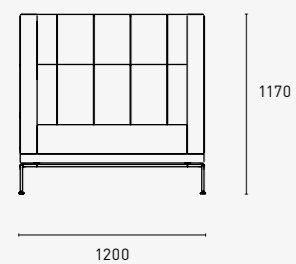

Side

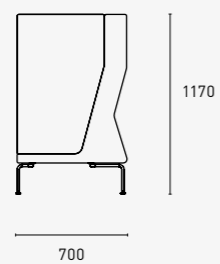

Top

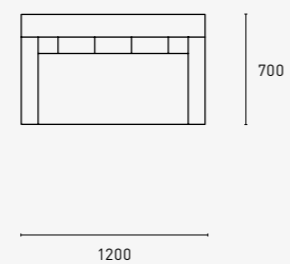

Krossi Table

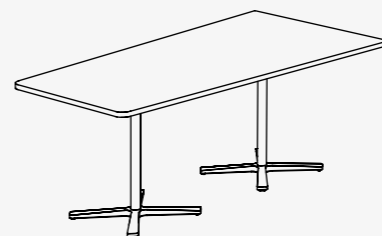

Krossi 4-star base

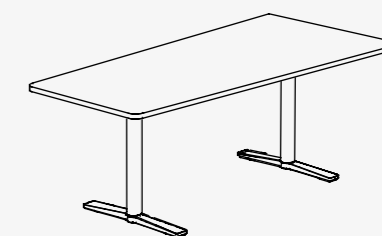
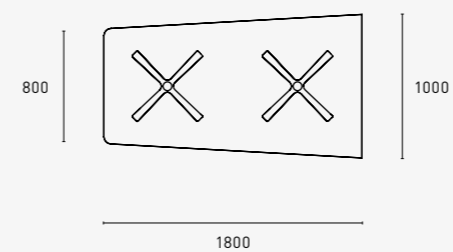

Krossi T-Leg

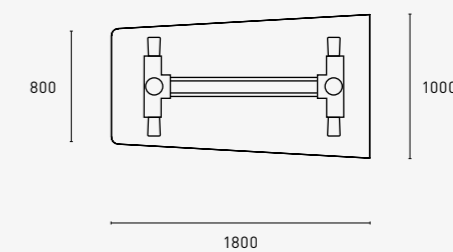



Certified Green

Ecology and Sustainability

Schiavello's most important commitment to sustainability is the company-wide Environmental Management System under ISO 14001. The environmental design principles realised means we design for the environment, focusing on efficient energy use and minimum emissions, longevity and durability, re-use and recycling of our products.

Our principles of ME WE (Materials, Energy, Waste, Emissions) give us a simple way to think how our operations impact the environment.



To find a Schiavello Showroom or partner in your area, please visit **[schiavello.com/location](https://www.schiavello.com/location)**.

1 – Community

A community is a social unit of any size that shares common values.

In human communities, intent, belief, resources, preferences, needs, risks, and a number of other conditions may be present and common, affecting the identity of the participants and their degree of cohesiveness.

