

Pocket  
02

Una storia italiana | An Italian story

 **Diemme**

SEATS STORY

 **Diemme** Collezione | Collection

Una storia italiana | An Italian story

### Attesa / Meeting

MARGARITA	6. 11
CLEA PLUS	12. 15
CLEA	16. 17
MISS	18. 25
MISS LOUNGE	26. 27
MISS SGABELLO	28. 29
PRINCE	30
RED HOT	31
OBLO'	32. 33
EON	34. 45
VANITY	46. 51
DAMA	52. 55
KONTE'	56. 59
MISTER	60. 61
TRONIX	62. 63
ORIGAMI	65. 67
PASS	68. 69
YOGA	70. 71
LIZ	72. 77
DOUBLE	78. 81
CIRCUIT	82. 93
CIRCUIT PRIVE'	94. 95
TOFFEE	96. 97
JAZZ	98. 99
SQUARE	100. 101
BREAD	102. 109
HALL	110. 113
FRAME	114. 115
QUBIQ	116. 117
CROSS	118. 121

### Tavolini / Tables

BREAD	124. 127
CLOCK	128. 129
XL - XS	130. 131

### Direzionali / Executive

HALFPIPE	134. 143
MOON	144. 147
DAMA	148. 151
AUCKLAND	152. 155
VENUS	156. 159
ARTÙ	160. 163
QUEEN	164. 165
LIZ	166. 167
STYLE	168. 169
NEST	170. 171
DUKE	172. 173

### Operative / Task

LEAD	176. 179
FIT	180. 187
FIT UP	188. 191
GOAL	192. 197
FLASH	198. 201
KEY	202. 203
FIVE	204. 205
FREE	206
FREE MESH	207
DUBLINO	208. 209
BINGO	210. 211

### Collettività / Community

OXFORD	214. 215
AIRA	216. 217
SLIM	218. 225
SOCIAL	226. 229
ICE	230. 233
ZETA	234. 237
SUNNY NEW	238. 241
BONN	242. 245

Rivestimenti / Upholstery	249. 259
------------------------------	----------

Caratteristiche tecniche / Technical detail	262. 303
--	----------

# Living/Meeting Area

attesa / riunione



## Margarita



Semplici e funzionali, questi piccoli tavoli rotondi dal design estremamente essenziale e minimalista giocano il ruolo di complemento alla poltroncina Margarita.

Sono disponibili in due diverse misure e in varie colorazioni. Raffinato piano d'appoggio vicino alla poltroncina questo tavolino è un oggetto versatile che si presta all'uso in diversi ambienti.

Simple and practical, these small round coffee tables with an extremely essential and minimalist design complement the Margarita armchair.

They come in two different sizes and a range of colours.

This versatile coffee table can be used in a variety of settings. It provides a refined surface next to the armchair.



## Margarita

Dining table adatto sia per indoor che per outdoor; leggero e versatile, dal look minimale, è perfetto per luoghi pubblici ma può essere facilmente collocato in altri ambiti; in ufficio o a casa si trasforma in un piano d'appoggio ideale, estensione della scrivania o supporto al divano. In questa versione le gambe convergono nel centro del piano, conferendone un senso di grande leggerezza.

This light, versatile dining table with a minimal look can be used both indoors and outdoors.

It is perfect for public places, but it can also fit easily into other settings in an office or a home it is ideal for providing a surface alongside a sofa or extending a desk.

The legs of this version have been shifted towards the centre of the surface, giving it a sense of great lightness.





## Clea Plus

Giovinchezza, versatilità e comfort sono le parole chiave della personalità di Clea Plus, una sedia proposta con diverse basi pronta ad entrare in sintonia con qualsiasi ambiente e a proporre abbinamenti inattesi nei materiali e nei colori, sia per l'ufficio che per il contract.

The character of Clea Plus can be summed up in three words: youthful, versatile and comfortable. With its selection of bases, the chair is the perfect match for any setting. All sorts of breathtaking combinations of materials and colours are possible, to cater to the needs of both offices and the contract market.







## Clea Plus



Clea Plus è un modello dal design semplice ed elegante, creato per sale d'attesa, comunità e contract. La seduta spaziosa è imbottita con poliuretano espanso, per garantire il massimo comfort. Per il rivestimento è possibile scegliere in una vasta gamma di tessuti, pelli e colori.

Clea Plus has a simple, stylish design that was conceived for waiting rooms, public spaces and the contract market. The spacious, cosy seat is padded with polyurethane foam for maximum comfort. A vast range of fabrics and colours are available for the upholstery.



## Clea

Clea, più che una sedia è una piccola poltroncina creata per aree collettive; si caratterizza per i contenuti di design e funzionalità, determinata questa da elevati livelli prestazionali e dal confort della seduta, assicurato anche in situazioni prolungate.

Clea is actually a small armchair that has been created for public spaces. It combines a stylish design with practical aspects such as exceptional performance and guaranteed comfort from the seat even during extended use.

## Miss

Ergonomia come principio fondamentale; tecnologia e semplicità si fondono poi in un'unica soluzione. Leggera nello stile, solida nei contenuti, è resa esteticamente accattivante grazie ad una linea minimalista e pulita. Miss è dotata di un meccanismo oscillante che permette di regolare l'altezza e l'inclinazione della seduta. Questa versione è stata pensata per l'ufficio operativo, offrendo una seduta confortevole anche per molte ore di lavoro.

Ergonomics is a fundamental principle; technology and simplicity are blended in a single solution. With its uncomplicated style and sturdy construction, the Miss chair boasts a sleek, minimalist style. This chair features a knee-tilt mechanism that makes the seat both height and tilt adjustable. This version has been specifically designed for office use, because it delivers exceptional comfort even after prolonged use.



## Miss

Miss è un modello prestigioso e dalla spiccata personalità, un classico dalla linea contemporanea in cui design, comfort e funzionalità si fondono assieme in un equilibrio armonioso. Raffinato il disegno, curati i dettagli, selezionati i materiali; la preziosa lavorazione a trapunta nobilita il modello conferendogli grande eleganza e raffinatezza. Un gusto classico interpretato in chiave attuale con grande coerenza in uno spirito moderno, ideale per diverse interpretazioni.

Miss is a prestigious model with a strong personality. Its classical style with modern touches blends design, comfort and functionality. Its sophisticated design is the result of meticulous details and selected materials, and the beautiful quilted back adds just the right touch of refined elegance. The Miss chair provides a modern interpretation of a classical style, and becomes suitable for modern work environments of any type.





## Miss

La vivacità dei colori, le forme attuali e la modernità dei materiali rendono il modello protagonista di ogni ambiente. Le imbottiture avvolgono la seduta mantenendo inalterata l'essenzialità del disegno, offrendo un relax a tutto tondo. Il bracciolo in tondino di metallo cromato attraversa lo schienale con un segno netto e gradevole.

The vibrant colours, contemporary forms and modern materials mean that this model will be the centrepiece of any setting. The seat is wrapped in generous padding that promotes all-round relaxation without detracting from the essentiality of the design. The thin, round chromed armrests cross the backrest in a pleasingly clean-cut way.



## Miss

La versione imbottita con gambe offre una seduta fissa ma estremamente confortevole, ideale per l'ambiente attesa. La particolare trapuntatura conferisce valore estetico ad una forma essenziale ma ricercata.

The upholstered version with legs is a fixed yet extremely comfortable seating solution that is ideal for waiting rooms. The beautiful upholstered cover lends a touch of chic beauty to a simple yet sophisticated shape.



## Miss

Miss è un'innovativo e funzionale programma concepito per soddisfare le pressanti esigenze di interattività lavorativa. Le molteplici varianti garantiscono possibilità combinatorie e modulari con effetti estetici e funzionali sempre diversi. La sinuosità dello schienale oltre ad essere una scelta estetica è soprattutto ergonomica perché aumenta il confort della seduta supportando lo spettatore durante le ore di permanenza nella sala.

Miss is an innovative and practical range that is designed to satisfy the pressing need for interaction in the workplace. Countless visual and functional effects can be produced with modular arrangements and combinations of the many different versions. While it is also aesthetically pleasing, the winding shape of the backrest is first and foremost an ergonomic design choice because it makes the chair more comfortable by supporting spectators during their time in the room.



## Miss Lounge



E' una seduta che completa la gamma Miss, oggi sicuramente uno dei modelli di punta della nostra produzione. Le raffinate finiture cromate, il particolare design della base che fa da supporto anche allo schienale in tondino di metallo cromato esaltano l'attualità di Miss Lounge. Preziose cuciture, anche a contrasto, realizzabili su richiesta nei rivestimenti in pelle ed ecopelle danno un notevole fashion appeal alla seduta sottolineandone l'essenzialità formale.

This model completes the Miss range and is undoubtedly one of the flagship models of our entire collection. A sophisticated chromed finish and the stylish base that also supports the chromed metal pipe back make the Miss Lounge chair even more modern. Beautiful tone-on-tone or contrast stitching - available on request for the leather and faux leather versions - lend an unmistakable finishing touch to the formal style of this model.



## Miss sgabello



Questo sgabello dalle generose dimensioni è un'originale alternativa alle normali sedute "alte" ed è progettato all'interno di un design unitario che permette la più completa accostabilità delle varie sedute nei diversi usi e funzioni. L'essenzialità della forma e l'attualità dei colori fanno di Miss sgabello la seduta ideale per personalizzare in modo innovativo spazi collettivi o domestici dotati di forte personalità. La leggera struttura in tondino di metallo cromato conferisce leggerezza ad un sedile comunque importante.



This generously sized stool is an original alternative to normal "tall" seats. It is part of a harmonious design scheme that gives full scope for all of the seats to be matched together as they serve their different purposes and functions. The clean-cut shape and contemporary colours make Miss stool the ideal seat for innovative customization of public spaces and household settings with strong personalities. The thin round chromed frame gives a sense of lightness to the structure of the seat, which is nonetheless genuinely substantial.





## Prince



## RedHot

Il filo conduttore è la leggerezza; tutta la serie Redhot si contraddistingue per linee eleganti e spessori sottili esaltati da un design puro ed essenziale. Due i basamenti disponibili per una seduta che garantisce ergonomia e confort anche in uno sgabello.

Lightness is the common thread running throughout the Redhot range, whose pure, simple design brings out the best of the graceful lines and slender forms. A choice of two bases is available for the seat, which also guarantees ergonomics and comfort in the form of a stool.



## Oblò



Esile, aereo, quasi sospeso sulle alte gambe in tubolare di metallo piegato, coniuga due diversi materiali in modo naturale attraverso dettagli raffinati e proporzioni accurate che conferiscono identità ed eleganza al modello.

This slender, airy stool almost appears to float on its tall, bent metal tubular legs. The two different materials seem a natural match for each other thanks to the refined detailing and precise proportions, which give the piece its elegance and identity.



## Oblò



> Caratterizzato da una seduta imbottita estremamente ergonomica, Oblò è uno sgabello dal design giovane, spiritoso, innovativo e dal grande confort. Una seduta comoda e sicura, e con un aiuto in più: la base oscillante segue i movimenti del corpo garantendo massima presa a terra.

> Oblò is a stool with a vivacious, innovative and extremely comfortable design, featuring a highly ergonomic padded seat. A comfortable, steady seat that offers a helping hand: the rocking base follows the movements of the body and guarantees maximum adherence to the ground.



## Eon

Il sistema Eon si presenta in varie versioni, anche come sgabello, adattabile a banconi o tavoli alti. Tre le tipologie di basamento, a quattro gambe, a slitta e su telaio girevole tubolare. La versione su ruote viene proposta per il settore home office. La seduta è disponibile sia in poliuretano rigido TECH® oppure imbottita e completamente rivestita in tessuto o pelle, anche bicolore.

Eon system is available in different versions, as well as stool, adaptable to high tables or counters. Three types of base, four legs, slide and swivel tubular frame. The version on castors is proposed for home office sector. The shell is available in both rigid polyurethane TECH® or completely upholstered and covered in fabric or leather, also bicolored.



# Eon



La leggerezza delle sedute Eon e le varie tipologie di basamento, dai telai alla panca, creano uno splendido contrasto che si armonizza perfettamente con gli ambienti più svariati. Le linee sinuose ed avvolgenti, la trasversalità e praticità del prodotto, conferiscono agli spazi un valore aggiunto di modernità e al contempo di eleganza. , la trasversalità e praticità del prodotto, conferiscono agli spazi un valore aggiunto di modernità e al contempo di eleganza. , conferiscono agli spazi un valore aggiunto di modernità e al contempo di eleganza.

The lightness of Eon and the various types of bases, from the frames to the bench, create a beautiful contrast that harmonizes perfectly with the many different environments. The sinuous and softlines, versatility and practicality of the product ,confer to the spaces an add value of modernity and at the meantime of elegance. environments. The sinuous and softlines, versatility and practicality of the product ,confer to the spaces an add value of modernity and at the meantime of elegance. ,confer to the spaces an add value





## Eon

Questa seduta è caratterizzata da un design pulito ed avvolgente, da un elevatissimo livello di confort e da una fantastica adattabilità ad ogni tipo di configurazione d'arredo. Il modello offre un mix armonico ed equilibrato tra valenze estetiche e qualità funzionali con uno stile innovativo nel rispetto della tradizionale qualità. Il bracciolo in tondino di metallo come la struttura si aggancia ad essa donando continuità e uniformità alle linee. La seduta, dall'aspetto quasi "organico", è realizzata in TECH® schiumato a freddo e assicura un'inalterabilità nel tempo.

This clean-cut, enveloping seat offers exceptional comfort and can fit in marvellously in any interior design scheme. It offers a harmoniously balanced blend of aesthetic values and functional properties, with innovative style and the usual high quality. The armrests are made of the same thin round metal tubes as the structure and they interlock with it, giving a sense of continuity and uniformity to the lines. The TECH® cold foam seat will remain unaltered over time and it has an almost "organic" appearance.



## Eon



Un design raffinato giocato sul contrasto di colori mette in risalto i dettagli e le particolari e preziose finiture. Eon stimola la creatività per arricchire di nuove emozioni l'ambiente di lavoro, gli spazi collettivi, i luoghi conferenziali, l'ambiente domestico o il contract, soddisfacendo sia l'aspetto ergonomico che quello d'immagine e di funzionalità.

The refined design plays with contrasting colours and highlights the details and the distinctive, exquisite finishes. Eon offers creative stimulation to inject fresh sensations into working environments, public spaces, conference venues, homes and contract settings, satisfying ergonomic, image-related and practical needs.



## Eon

Semplicità ed essenzialità con un design incisivo e riconoscibile, fanno di Eon una linea di sedute giovane e simpatica, facilmente adattabile a qualsiasi ambiente, nel quale assume un ruolo da vera protagonista e risponde concretamente ai principi di ergonomia, funzionalità, flessibilità e personalizzazione del proprio spazio. Caratterizzata dalla particolare e unica forma della seduta, la collezione Eon si distingue per un elevato grado di praticità, per l'accuratezza delle finiture, e soprattutto per le sue possibilità multiuso.

Simplicity and essentialness with an incisive and recognizable design make of Eon a young and nice line of chairs, easily suitable to any environment, in which assumes a role as protagonist and responds specifically to the principles of ergonomics, functionality, flexibility and customization of your own space. Characterized by an original and unique shape of the chair, Eon collection is distinguished for a high level of practicality, for the accuracy of the finish, and especially for its multipurpose possibilities.





## Eon

Oltre alla versione completamente imbottita e rivestita è disponibile anche la versione "nuda", la quale esalta fortemente l'aspetto estetico del prodotto. La leggerezza della forma e la sinuosità della linea creano uno splendido contrasto che si armonizza perfettamente con gli ambienti più diversi. Eleganza, design e funzionalità si ritrovano in un'unica struttura. Avvolgenti e morbide curve qualificano le aree di accoglienza rendendole morbide e confortevoli.

In addition to the fully upholstered version it is also available the "naked" version, which greatly enhances the appearance of the product. The lightness of shape and the sinuous lines create a beautiful contrast that harmonizes perfectly with a variety of environment. Elegance, design and functionality are mixed in a single structure. Round and soft curves qualify the areas of reception making them soft and comfortable.







## Vanity

Vanity è stata sviluppata con l'intento di soddisfare sia l'aspetto ergonomico che quello d'immagine del sempre più attento ed esigente utente finale. Nasce così un programma caratterizzato da un design raffinato e da prestazioni ergonomiche eccellenti, realizzato utilizzando diversi basamenti per coprire qualsiasi esigenza funzionale sia nell'ambiente di lavoro, sia nell'ambiente domestico.

With its ergonomic details and beautiful style the Vanity model will definitely suit the requirements of even the most demanding users. The chairs of this collection are characterized by unrivalled ergonomic features and sophisticated design, and are available with different bases that make them ideal for homes and offices alike.



## Vanity

Una sensazione unica di bellezza e di confort traspare da ogni particolare che è studiato con la massima cura per ottenere un prodotto di straordinaria qualità. Vanity è la poltrona per chi desidera circondarsi di oggetti d'arredo preziosi e di design, ma anche estremamente confortevoli. L'imbottitura della seduta prosegue nello schienale, integrando in un tutt'uno la sua linea unica e raffinata.

A unique feeling of comfort and beauty exudes from every single detail, which is meticulously designed in order to deliver top quality. The Vanity chair will meet the requirements of people who like to be surrounded by stylish furnishing items that not only look good but are also comfortable. Both the seat and the back are padded for a more sophisticated visual effect.



## Vanity

Molto trendy sia nella versione fissa che girevole su ruote, Vanity risulta essere un modello estremamente versatile per qualsiasi tipo di personalizzazione. E' la seduta ideale per un ambiente in cui l'attenzione per l'eleganza ed il rigore formale diventano importanti. La base in metallo cromato, dal design moderno ed innovativo, conferisce estrema stabilità alla seduta.

Both in the fixed version or swivel on casters, Vanity is an extremely trendy and versatile model that can be customized in so many different ways. It is the ideal solution for environment where elegance and formal rigour are the main prerequisites. The stylish base in chromed metal adds stability to the chair and has an innovative design.







## Dama

Leggera nello stile, solida nei contenuti, Dama è resa esteticamente accattivante grazie ad una linea minimalista e pulita. Tecnologia e design si fondono poi in un'unica soluzione. Un'ampia gamma di soluzioni funzionali rende Dama un oggetto di largo utilizzo e di grande impatto visivo. La semplicità delle sue forme è ingentilita da pregiati dettagli.

Dama's slender style is counterbalanced by its solid content, while its minimal, clean-cut lines really catch the eye. It all revolves around the ergonomics, as technology and design merge in a single solution. Dama is a visually stunning piece that is in widespread use thanks to its broad functional scope.





## Dama



Un'ampia gamma di versioni rende la poltroncina Dama un oggetto di grande duttilità e di grande impatto visivo. Con l'elegante semplicità del suo disegno, dal grafismo essenziale e di grande pulizia formale, consente di arredare ambienti di diverso stile e utilizzo personalizzandoli con discreta eleganza.

The Dama range of armchairs is both striking and extremely flexible thanks to the many different versions on offer. The elegant simplicity of the design and the essential, clean-cut form mean that it is ideal for furnishing and adding a dash of discreet elegance to settings with many different styles and uses.



## Kontè

>Una linea continua che unisce il classico e il moderno. Kontè ripercorre la storia della sedia reinterpretandola nel gusto dei nostri giorni.

Rappresenta la massima maestria delle lavorazioni e dei dettagli applicata al rivestimento, sia in tessuto che in pelle.

>An unbroken line between the classic and the modern. Kontè retraces the history of the chair and gives it a fresh twist to suit contemporary tastes.

It is the epitome of unparalleled workmanship and bringing out the best of details in both fabric and leather upholstery.





## Kontè

L'eleganza s'identifica nei dettagli e nel confort grazie alle particolari imbottiture, progettate per offrire un'avvolgente ergonomia. The detailing and comfort add a very stylish touch. The distinctive padding has been designed to offer enveloping ergonomics.





## Mister

Un' intramontabile seduta per l'ambiente attesa, Mister si caratterizza per la leggerezza delle forme. Innovativo il design: un pannello di seduta agganciato a due che fanno da struttura portante e bracciolo. Mister è la seduta ideale per luoghi dallo spirito moderno, sia per l'attesa veloce che per l'intrattenimento.

Mister's distinguishing feature is the lightness of its form, Mister is characterized by the lightness of the forms. Innovative design: a panel session hooked to two that form the supporting structure and armrest. Mister is the ideal seat for places of the modern spirit, both for the expected faster and for entertainment.







## Tronix

Una sensazione unica di bellezza e di confort traspare da ogni particolare che è studiato con la massima cura per ottenere un prodotto di straordinaria qualità. Tronix è la poltrona per chi desidera circondarsi di oggetti d'arredo preziosi e di design, oltrechè confortevoli. Ogni aspetto, sia tecnico che qualitativo o estetico, è di ottimo livello perchè ogni suo particolare è curato con la massima attenzione per offrire un prodotto confortevole e raffinato. Optional la tavoletta sul bracciolo, ideale in occasione di riunioni e meeting di lavoro.

Every single detail has been specifically designed to provide a successful combination of beauty and comfort: the result is a top-quality product. Tronix is a chair designed for people who like to be surrounded by precious stylish objects that nonetheless also need to be comfortable. Every single technical and visual aspect is of top quality because it is meticulously designed in order to be comfortable and look sophisticated. An optional tablet can be mounted onto the armrest, for use during work meetings.



A volte l'aspetto estetico, l'insieme delle forme, il design, sono gli elementi che fanno nascere in noi il desiderio per un determinato oggetto. Altre volte sono i contenuti tecnici ed ergonomici quelli che indirizzano, magari in modo più razionale, le nostre scelte. Di fronte ai nostri prodotti poche possono essere le esitazioni perchè ogni aspetto, sia tecnico che qualitativo o estetico, è di altissimo livello.

## Origami



Origami è una poltroncina d'alta gamma per conferenze e congressi, progettata per il piacere di una seduta esclusiva.

La rigorosa geometria della seduta ci parla di coerenza concettuale, di materiali scelti accuratamente e sapientemente lavorati, di ambienti importanti e accoglienti per i quali è stata ideata; funzionalità e confort confermano il dominio dell'intelligenza creativa che sottende il progetto. Design di alto impatto estetico, materiali prestigiosi, finiture impeccabili e soluzioni tecnologiche d'avanguardia.

Origami is a high-end armchair for conferences and conventions. It is designed to offer the pleasures of exclusive seating.

The crisp shapes highlight the coherent concepts behind the seats and their carefully selected, masterfully worked materials. They evoke images of the welcoming, majestic surroundings for which these high performance armchairs were designed. The creative intelligence behind them is made plain by their practicality and comfort. The armchairs feature striking aesthetics, prestigious materials, impeccable finishes and cutting-edge technological solutions.



## Origami



È una collezione completa di poltrone per conferenza ad altissima resistenza che permette una grande affidabilità negli ambienti di grande afflusso e frequenza di pubblico.

La gamma Origami offre numerosi accessori e differenti finiture in grado di soddisfare ogni richiesta, come la versione con tavoletta antipanico ribaltabile, alloggiata a riposo nel bracciolo, completamente pieghevole con pochi e semplici gesti, è facilmente accostabile grazie ad un semplice aggancio posto ai piedi del fianco.



This comprehensive collection of highly durable armchairs for conferences presents extremely reliable solutions for settings where large numbers of people gather on a regular basis. There are numerous accessories and finishes to suit all needs in the Origami range, such as a version with a folding anti-panic tablet with a bracket slotted in the armrest, which is perfect as a laptop support. The chairs are completely foldable. They can be joined together in an instant thanks to the simple links on the bottom of the sides.

## Pass

Pass è l'innovativa evoluzione del classico pozzetto, modello di riferimento storico nell'ambito delle poltrone multifunzionali. Originale e d'elegante, è dedicata a chi desidera di più nello stile, nelle dimensioni, nelle finiture, nel confort, mantenendo immutate le linee di un design pulito e attuale che offre grande versatilità per arredare ambienti dagli stili più diversi, dal classico al più moderno.

Inoltre è possibile allineare le poltrone per creare una sala convegni di grande prestigio con la configurazione che si preferisce.

Pass is an innovative new take on the tub seat, which is a long-standing classic in the world of multi-purpose armchairs.

Original and elegant, it is dedicated to those who want more in terms of style, size, finish and comfort, while still maintaining the lines of a clean-cut, contemporary design that offers highly versatile furnishing solutions for settings with styles of all kinds, from traditional to ultra-modern.

In addition, the armchairs can be arranged in countless formations, for highly prestigious conference halls.



# Yoga

Funzionale, flessibile ed ergonomica, Yoga è un guscio colorato di confort in vesti di raffinato design. Linee sinuose e morbide sottolineano la struttura e le proporzioni di una seduta adatta ad ogni tipo di ambiente, dalle reception più sofisticate, alle attese moderne e minimaliste. Yoga: una poltrona di alto livello, dotata di uno stile inconfondibile e senza tempo.

Functional, flexible and ergonomic, Yoga is a colourful shell that blends comfort with sophisticated design. The gentle lines of this chair are perfect for any environment, from sophisticated waiting areas to modern minimalist reception areas. Yoga is a top-level chair with a distinctive style that will last for generations.





Caratterizzato da forme leggere e sinuose, questo è un programma che aggiunge alla tradizionale eleganza degli studi direzionali alcuni elementi ormai indispensabili al posto di lavoro di un moderno manager. Elegante nello stile, essenziale nel design e tecnicamente evoluta, la serie Liz interpreta, con ricercata professionalità, le aspettative di chi vuole affermare il proprio ruolo e la propria personalità, garantendo, attraverso le soluzioni di design più attuali, un alto livello di qualità e confort.

Featuring light and sinuous forms, this is a collection that adds to the traditional elegance of the executive offices some elements indispensable in the workplace of a modern manager. Elegant in style, essential in design and technically advanced, the Liz collection meets, with high professionalism, the expectation of those who want to affirm its role and personality, ensuring, through solutions of design, a high level of quality and comfort.

## Liz

Fuori dai soliti schemi delle poltroncine tecniche, Liz offre un'immagine raffinata ed elegante adattabile a qualsiasi tipologia d'ambiente, purchè importante e prestigioso. Soluzione ideale in quanto a confort e qualità, è caratterizzata da forme sinuose e delicati volumi ben proporzionati, tali da rendere Liz un prodotto d'insieme assolutamente armonioso. La poltroncina fa parte della famiglia allargata Liz, composta da poltroncina, divanetto e sedia direzionale che, insieme, consentono un arredamento completo sia per l'attesa che per l'ufficio.

With its unconventional style, the Liz chair has an elegant, sophisticated design that suits any type of environment where style and prestige are the central features. Liz is the ideal chair that blends comfort with quality, and is distinguished by curvaceous shapes and delicate, well-balanced volumes. The resulting visual effect is absolutely harmonious. This chair belongs to a wider range, which includes chairs, sofas and executive chairs designed for offices and waiting rooms.





## Liz

Liz è la soluzione ideale per ottenere risultati eccellenti in termini di confort e qualità. Caratterizzata da dimensioni contenute, è frutto di un design accurato che offre linee attuali e dinamiche per un insieme che unisce il design a materiali pregiati. Soluzioni ideali per ambienti d'attesa eleganti e razionali.

Characterized by important and large dimensions, Liz is the result of a careful design that offers, along with high ergonomics, current and dynamic lines for a product that combines the finest materials to design. Thanks to this special design it is possible to obtain an excellent result in comfort and quality.





## Double

Il programma prevede la poltrona nelle due versioni aperta e chiusa, e il divano due posti nella sola versione aperta. Anche il divano può accostarsi alla poltrona chiusa consentendo molteplici e fantasiose composizioni oltremodo comode e rilassanti..

This collection features the same model of chair in the open and closed version, and a two-seater sofa only available in the open version. If you place the sofa next to the closed chair, you can create an innovative seating solution.



## Double



Double è una poltroncina dal design fortemente distintivo lavorata con tecniche e materiali d'avanguardia. Denominatori comuni e imprescindibili sono ovviamente l'estetica e il confort. Grande anche la capacità manifatturiera nel vestire spigolosità e morbidezze che un curato design hanno ideato.

Double is an armchair with a highly distinctive design worked with technical and advanced materials. Common denominators are essential and of course the aesthetics and comfort. Also great manufacturing capacity in dress sharpness and softness that an accurate design have created.

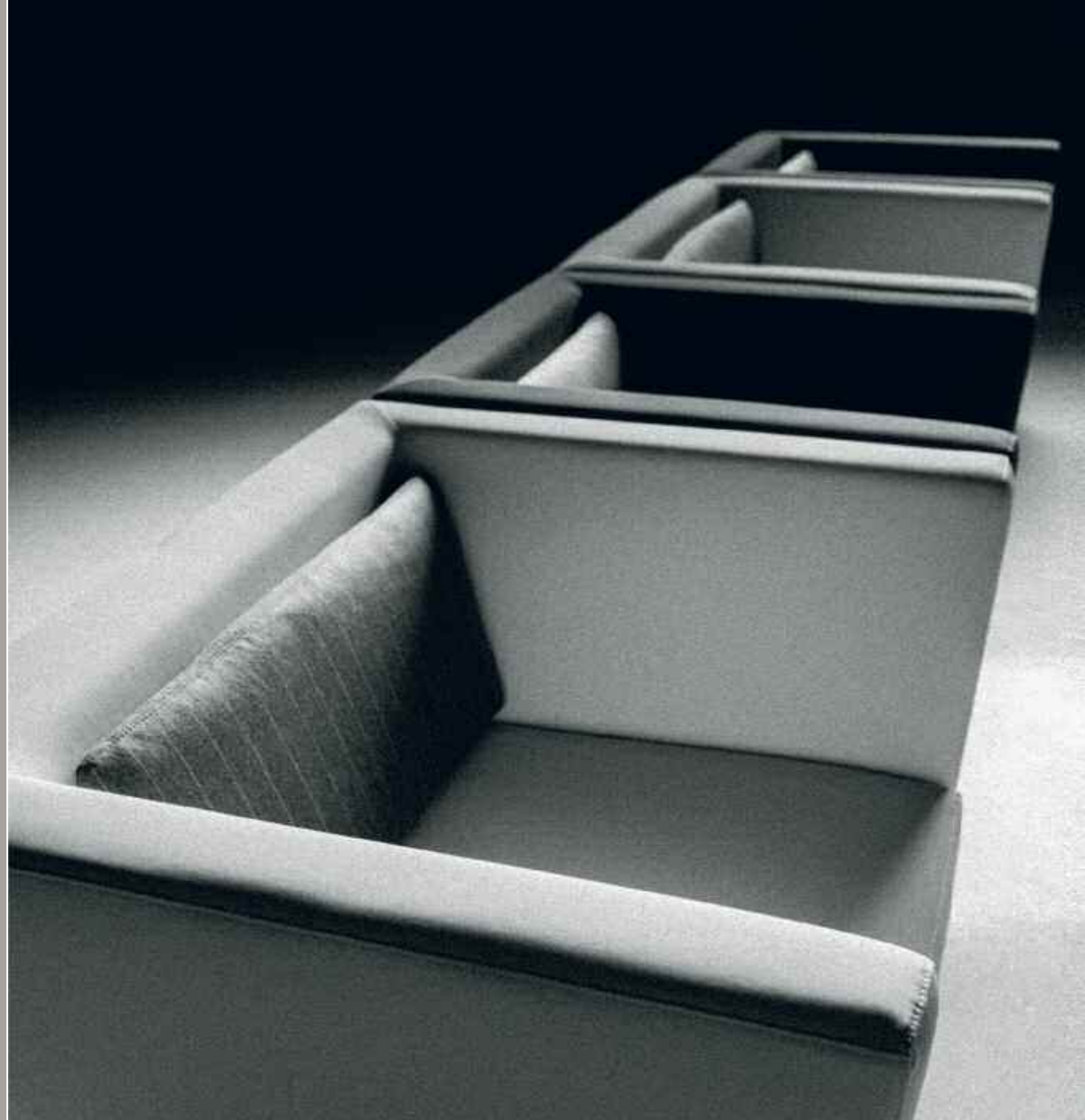

## Circuit



La collezione Circuit nasce con l'intento di soddisfare sia l'aspetto ergonomico che quello d'immagine del sempre più attento ed esigente utente finale. Nasce così un programma componibile caratterizzato da un design semplice ed elegante, da prestazioni ergonomiche eccellenti e da una componibilità vasta e versatile che gli consente di essere utilizzato in ambienti diversi sia per esigenze di spazio che per esigenze funzionali. La concretezza delle forme ben rispecchia la solidità dei contenuti di questo progetto che ridisegna, con creativa semplicità e razionale modularità, gli spazi collettivi.

The Circuit collection was conceived to meet both the ergonomic and aesthetic requirements of an ever more demanding end usership. From this was born a modular system distinguished by simple and elegant design, excellent ergonomic performance, and a vast and versatile array of configurations which allow it to be used in any number of types of area whether for space or functional considerations. The tangibility of Circuit's shapes perfectly reflects the substantial content of this project which redesigns public spaces with simple creativity and considered modularity.



Circuit





Un'ampia gamma di soluzioni e possibilità funzionali rende Circuit un oggetto di largo utilizzo e di grande impatto visivo, seduta ideale per ambienti in cui eleganza e rigore formale vengono messi in primo piano. Studiata con la massima cura in ogni minimo dettaglio per chi desidera circondarsi di oggetti d'arredo di design, oltrechè confortevoli.

A rich range of solutions and functional possibilities gives Circuit an immediate visual impact and allows widespread use, your ideal seating for when elegance and formal style are top priorities. Conceived with the greatest attention to every tiny detail for those who want to surround themselves with both comfortable and designer furniture.

## Circuit



## Circuit

Gli ambienti risultano gradevoli quando tutti gli elementi convivono in armonia di forme e colori.

La collezione Circuit è completata da un piccolo tavolino dalla linea slanciata, esile ed elegante grazie al sottile basamento in tubolare di metallo verniciato nello stesso colore del piano.

Space planning has a satisfying outcome when all its constituent parts co-exist harmoniously both colour and design wise. The Circuit collection is completed by a delightfully sleek and slanting coffee table, thanks to its metal tube base lacquered in the same colour as the top.



## Circuit

La versione a schienale basso può essere abbinata nello stesso ambiente a quella a schienale alto, determinando diverse situazioni e funzioni. Lo schienale alto viene utilizzato come separatore di sedute, creando spazi privati tête-à-tête. Molto più libera e conviviale la versione aperta a schienale basso.

The lower-backed version can be used alongside its higher-backed counterpart, throwing up a range of functions and formations. The high-back can be used as a partition, creating private tête-à-tête areas. Much freer and more sociable is the open version with lower back.



## Circuit



Il programma Circuit consente di creare elementi ideali divisori e di partizione per spazi lounge, di relax e di attesa-reception. Il suo utilizzo spazia in contesti diversi, dall'ufficio open space alle sale riunioni e a tutti quegli ambienti pubblici dove lo spazio ridotto impedisce una corretta fruizione dell'ambiente.

The Circuit range can be used to create perfect dividers and partitions for lounge, relaxation and waiting/reception areas. They can be employed in a range of locations, from open space offices and meeting rooms to all public settings that could not otherwise be exploited properly due to size restrictions.







## Circuit privé

Il programma Circuit consente di creare elementi ideali divisori e di partizione per spazi lounge, di relax e di attesa-reception. Il suo utilizzo spazia in contesti diversi, dall'ufficio open space alle sale riunioni e a tutti quegli ambienti pubblici dove lo spazio ridotto impedisce una corretta fruizione dell'ambiente.

The Circuit range can be used to create perfect dividers and partitions for lounge, relaxation and waiting/reception areas. They can be employed in a range of locations, from open space offices and meeting rooms to all public settings that could not otherwise be exploited properly due to size restrictions.



## Toffee

Un design basato sulla simmetria degli elementi rende il modello molto razionale. Poche linee ben calibrate determinano una forma semplice ed elegante, garantendo un confort eccezionale; grazie all'incavo sulla parte frontale della struttura, il modello tende a non sporcarsi all'altezza dell'inevitabile appoggio dei piedi.

A symmetrical combination of elements is the distinguishing characteristic of a particularly rational design. A few well-balanced lines create simple yet elegant shapes that add to your exceptional comfort. Thanks to a recess on the front part of the frame, this model does not get dirty in the area where you rest your feet on.



Jazz



## Square



Square è una miscellanea di eleganza estetica e ottimi ingredienti. Le generose dimensioni e la pulizia delle linee caratterizzano il divano con discrezione e raffinatezza. Moderno formalmente e concettualmente, è un modello di forte impatto visivo e di grande contenuto di comfort, dall'ampia gamma di soluzioni compositive grazie ai numerosi elementi che compongono la collezione.

A blend of elegance and excellence. Generous dimensions and uncluttered lines are the features of the discreet, refined sofa. The result of modern styling, this model brings stunning good looks and great comfort to a wide range of units that provide numerous opportunities for composition.

Grande versatilità e razionale progettualità in forme semplici, squadrate, quasi basiche. Il pouf staccato può divenire seduta e accostarsi al lungo cuscino che all'occorrenza, e con un semplice spostamento, diviene una comoda e spaziosa chaise longue. Un sistema estremamente semplice che permette svariate possibilità compositive per adattarsi a qualsiasi esigenza di spazio.

Outstanding versatility and rational design are translated into simple squared shapes. The pouf can be used as a seating surface. If you add a long cushion to it, it becomes a comfortable and spacious chaise longue. characterized by important and large dimension, this extremely simple system can create endless modular solutions.



## Bread



La forza della semplicità è tutta qui. Forme essenziali e pulite, misurate nelle proporzioni, ricercate nei dettagli in cui design, eleganza, confort e praticità d'uso trovano un equilibrato punto d'incontro, offrendo la massima flessibilità per creare angoli di originale funzionalità e di facile inserimento in ogni tipologia d'arredo. Morbide imbottiture creano un soffice guscio di confort che poggia su eleganti piedini in legno. Una scelta agile, dinamica, in pieno stile contemporaneo, soluzione ideale per ottenere risultati eccellenti in termini di confort e qualità.



The strengths of a simple style: clean shapes, balanced proportions, sophisticated details and a successful combination of design, elegance, comfort and ease of use are synonymous with outstanding flexibility and create original solutions that will suit any environment. Our padded models create a soft haven of comfort on wooden feet. These are dynamic solutions that suit modern lifestyles.





# Bread



La componibilità è uno dei punti di forza di Bread, modello che dell'essenzialità e della semplicità fa la sua bandiera. Grande impatto visivo, grandi contenuti formali; la qualità dei materiali rende il divano estremamente confortevole e fruibile in varie situazioni. Può infatti essere collocato nel salotto di casa come nella hall di un ambiente pubblico, divenendo comunque il protagonista indiscusso della stanza. Si presta a varie tipologie di rivestimento, preferibilmente tinte unite.

Bread's trademark qualities are its simplicity and essentiality, while its modularity is one of its biggest strengths. The range has a striking visual impact, with exceptional shapes. The quality of the materials makes the sofa extremely comfortable and adaptable to countless situations. It will always be the undisputed star in any setting, from a living room in a home to a hall in a public building. It is ideally suited for various kinds of upholstery, preferably in solid colours.







## Hall

Una rigorosa ma vezzosa trapuntatura sullo schienale rende particolare il modello Hall, essenziale nelle forme ma molto confortevole grazie all'utilizzo di materie prime di alta qualità e arricchito nello stile da particolari dettagli. E' disponibile nella versione due o tre posti, poltrona e pouf/panca lunga. Il modello è ideale per sale d'attesa e hall dallo spirito moderno dove è richiesto un forte impatto estetico mixato a grande confort.

The formal quilting pattern on the backrest adds a unique touch to Hall, whose forms are simple but very comfortable thanks to the high-quality materials used.

It is possible to choose between a two-seater sofa, a three-seater sofa, an armchair and pouffe/long bench. The range is ideal for waiting rooms and halls that require a combination of great comfort and powerful visual impact.



## Hall

L'unica eccezione al rigore delle forme è data dalla semplice e discreta trapuntatura a forma di rombi accostati sullo schienale. Il piedino, verniciato canna di fucile, corre lungo tutto il fianco del divano creando quasi una cornice; pochi dettagli che fanno la differenza.

The austerity of the shape is only broken up by the simple, understated quilting in a rhomboid pattern on the backrest. The dark grey varnished legs stretch all of the way up the sides of the sofas, almost like frames: a few little details like this make all the difference.







## Qubiq

Qubiq è una proposta di gusto estremamente moderno in grado di assicurare una caratterizzazione dello spazio molto importante e che fa della semplicità e della razionalità i suoi principali valori. Ogni dettaglio è studiato in una soluzione compositiva caratterizzata da grande rigore e da massima funzionalità.

Simplicity and rationality are the main values of Qubiq, an extremely modern product that will strongly stamp its identity on its surroundings. Every single aspect plays a carefully considered part in an exacting and highly functional overall composition.





## Cross



Cross è una collezione di imbottiti che, grazie alla sua originale forma progettuale, riesce a creare composizioni particolari ed articolate, in grado di adattarsi a qualsiasi spazio con grande impatto visivo. Singoli o componibili, gli elementi sono composti da una base/pouf e da uno schienale ad innesto sulla stessa, che può essere collocato in due posizioni e in altrettante due versioni, concavo e convesso. Pochi elementi per una grande potenzialità compositiva.

Cross is a collection of soft seating which, thanks to its original shape, are perfect to create very special and complex compositions.

It is able to suit any kind of space with a high eye-catching result. Singles or modular, the elements include a base / pouf and a backrest that can be fixed on them, and which can be placed in two positions and even in two versions, concave and convex. Few elements are enough to create a great modular potentiality.

## Cross

Forme plastiche, quasi organiche quelle che caratterizzano la collezione Cross.

La collezione si presta ad abbinamenti particolari di tessuto, e a seconda dello stile che si sceglie, può diventare sia classica che moderna. Dalle lane alla pelle, dai velluti ai cotoni sono molti i tessuti nel nostro campionario che possono essere utilizzati con estro e fantasia per creare soluzioni uniche e personalizzate.

The forms in the Cross collection are pliant and almost organic.

The collection lends itself to distinctive fabric combinations, which can be classic or modern depending on the chosen style. From wool and leather to velvet and cotton, there are numerous materials in our range that can be used with a little creativity and imagination to produce unique, customized solutions.



Tables  
Living Office  
tavolini



## Bread



Materiali tradizionali rivisti in nuove forme per dare luce ad un progetto innovativo di tavoli dal design particolare, fuori dagli schemi comuni. Spigoli e rette non sono la base di partenza di questo progetto: tutto fluisce, sfugge.

New takes on traditional materials appear in an innovative assortment of tables with a distinctive design that has broken the mould. This selection does not start with corners and straight lines: everything flows elusively.



## Bread



La collezione Bread nasce con l'intento di essere un utile complemento a divani e poltrone dell'attuale collezione, e quindi oggetti neutrali facilmente accostabili a diversi generi di stile e design. Ecco quindi tavolini prettamente tecnici e altri con un gusto più tradizionale, con un occhio alla modernità ma con qualche retaggio classico. Il piedino in legno accostato al piano laccato sono sicuramente degli spunti tradizionali rivisti però sulla base di nuove tecnologie produttive.

The Bread collection was created as a useful way of complementing the sofas and armchairs in the current range, so it contains neutral items that are easy to match with different styles and designs. Some of the coffee tables are purely technical and others have a more traditional feel, with the odd classic hint alongside modern features. There are unquestionably traditional influences behind the wooden legs alongside the lacquered top, but they have been reworked using the latest production technology.





## Bread





## Clock



Una proposta semplice, basica per un oggetto esteticamente valido e soprattutto molto funzionale, in grado di assicurare una forte caratterizzazione dello spazio. Clock fa della semplicità e della razionalità i suoi principali valori. Utile come work table, è disponibile nei colori bianco o antracite.

Simplicity and rationality are the main values of Clock. This aesthetically pleasing and highly functional product takes a straightforward, basic approach but it can really make its mark on the identity of a location. It is a handy working table and it comes in dark grey and white.



Poche linee ben tratteggiate: è il profilo di questo tavolino disponibile nella versione piccola Xs e nella più grande e più bassa XI. Il basamento è formato da una lama di metallo piegata ad incrocio e verniciata in bianco o nero per abbinarsi alla tonalità del piano.

A few well-drawn lines form the profile of this table, which comes in a small "Xs" version and a larger, lower "XI" version. The base is made of sheet metal bent into a cross, which can be coated in black or white to match the hues of the broad, thin top.



Executive  
Office  
area direzionale





## Halfpipe

is designed to provide the perfect setting for people to sit and work

## Halfpipe

La collezione propone un arredamento completo attraverso un prodotto versatile, innovativo, in grado di essere ad un tempo bello e comodo. Una linea di attesa unica, che è in grado di guardare al mondo dell'arredo in modo originale. Seduta importante con prestazioni di confort di livello assoluto. L'imbottitura prosegue sul bracciolo, integrando in un tutt'uno la sua linea unica e raffinata. Meccanismi di regolazione di altissima qualità, diversi tipi di braccioli, materiali e finiture al top di gamma, nulla è lasciato al caso in questa seduta che unisce prestazioni e design in modo ottimale.

The collection includes items with which to create a complete interior décor using a versatile innovative product that is both attractive and comfortable. Waiting room seating that furnishes with an original style, incorporating important seating with absolute comfort. The padding extends to the armrest to become one with the chair's unique refined lines. Prime quality regulation mechanisms, several types of armrests, materials and finishes are used so that nothing is left to chance in this chair that brings together optimum performance and design.



# waiting area



# Halfpipe

---





## Halfpipe

Stile, funzionalità e linee decise per una scelta vincente. Fascino bicolore e forte personalità: Halfpipe sta bene ovunque, vivace ed elegante con la sua silhouette snella e la base in metallo cromato a slitta che la enfatizza facendo tutt'uno con i braccioli. La concretezza delle forme rispecchia la solidità dei contenuti di questo progetto che ridisegna, con creativa semplicità e razionale modularità, gli spazi lavorativi.

Style, functionality and bold lines for a success product. Two-coloured charm and strong personality: Halfpipe looks good anywhere; lively and elegant with its slim silhouette set off by a chromed metal confilever base that blends with the armrests. The bold shapes reflect the sound contents of this project, which redesigns work space with creative simplicity and rational modularity.





## Halfpipe



Halfpipe è proposta in molteplici versioni, con diverse basi e diversi braccioli, il tutto all'interno di un design unitario che permette la più completa accostabilità nei diversi usi e funzioni. In un ambiente in continua evoluzione, l'aspetto legato all'ergonomia ha ricevuto un forte impulso verso il "total confort"; Halfpipe è l'esempio di come sia possibile coniugare un design elegante con un'ergonomia studiata e sviluppata per il massimo confort.

Un programma estremamente vario e completo di sedute operative che soddisfano appieno le esigenze del mondo lavorativo.

Halfpipe comes in many versions, with different bases and armrests, all incorporated in a single design that makes it perfect for several uses and functions.

In a continuously evolving environment, the ergonomic aspect has been strongly projected towards "total confort"; Halfpipe is an example of how elegant design and ergonomics for maximum confort can come together in harmony. The range is extremely wide and comprises taak chairs that fully meet the needs of the work place.



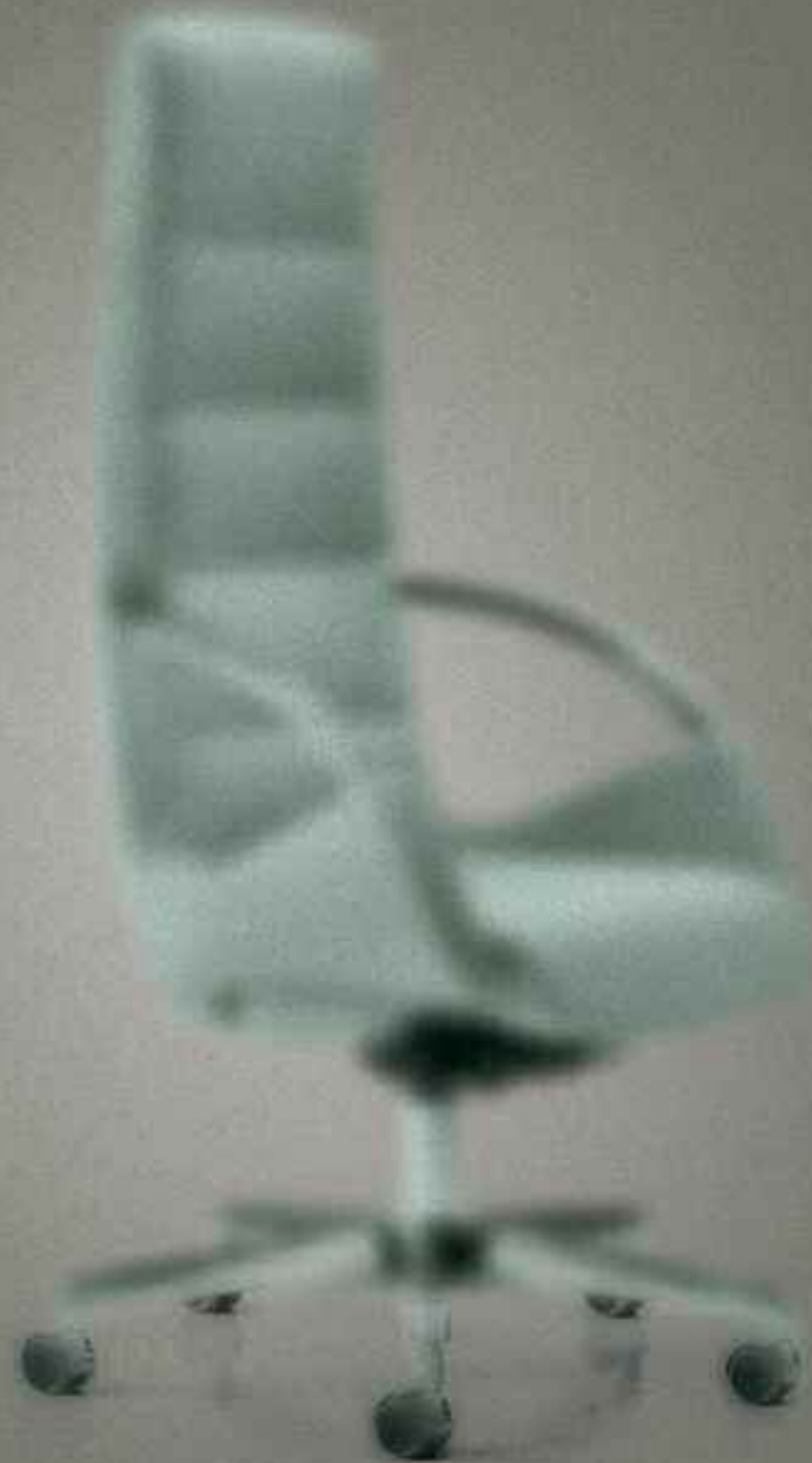

## Moon

Moon è un nuovo concept. Invece di esporre tutta la tecnologia ergonomica rendendo visibile strutture tipo esoscheletro, come molte recenti sedute, Moon incorpora tutto nel suo guscio flessibile e sinuoso. E' disponibile in tre versioni: con schienale alto, medio e basso. E' la seduta ideale per un ambiente di lavoro in cui attenzione per l'eleganza e rigore formale diventano importanti.

Moon stands for a new concept. Rather than translating ergonomic concepts into exoskeleton structures like the chairs you normally find in the market today, the Moon chair combines all components in a flexible curvaceous shell. It is available in three versions: low, medium or high backrest.



## Moon

Classico esempio di raffinato design italiano, con le sue linee morbide ma rigorose Moon coniuga estetica e funzionalità.

Si distingue per l'accuratezza delle finiture e per le sue possibilità polifunzionali con cui è possibile arredare spazi in cui coesistono funzioni di attesa e momenti di lavoro.

Moon is a classic example of refined Italian design that combines aesthetic appeal and practicality in its soft but precise lines. It stands out due to its meticulous finish and its multi-purpose potential for furnishing rooms that are used for both waiting and working.



## Dama

Prodotto formalmente e tradizionalmente elegante, Dama è una seduta polifunzionale ad alto contenuto di confort configurabile per gli spazi collettivi e di lavoro.

Il design originale e accurato viene valorizzato da materiali e finiture di pregio e da una ricca scelta di opzioni. Il suo particolare design la rende perfetta nelle situazioni che richiedono una seduta di carattere, nell'ufficio contemporaneo, in ambito conferenziale ed anche nell'ambiente domestico.

Dama is a formally and traditionally elegant product offering great comfort and multi-purpose solutions for working and public spaces.

The original, exacting design is marvellously set off by the fine finishing and materials, as well as the wide selection of options. The distinctive design means that it is perfect in locations that require seating full of character, in contemporary offices, conference venues and also in the home.

work and relax





## Dama



La collezione Dama nasce con l'intento di soddisfare sia l'aspetto ergonomico che quello d'immagine del sempre più attento ed esigente utente finale. Nasce così un programma caratterizzato da un design semplice ed elegante, da prestazioni ergonomiche eccellenti e da una versatilità che gli consente di essere utilizzato in ambienti diversi sia per esigenze di spazio che per esigenze funzionali.

The Dama collection was created to cater to the image and ergonomic requirements of increasingly alert and demanding end users. The resulting range features a simple, elegant design offering exceptional ergonomic performance and a degree of versatility that makes it perfect for settings with an array of different functional and space requirements.

## Auckland

Il mondo dell'ufficio guadagna maggiore leggerezza, velocità, efficienza, e duttilità grazie alle nuove tecnologie ed i nuovi sistemi di lavoro. Auckland è la sedia affidabile, veloce, efficiente e duttile per gli uffici di oggi. Dettagli in metallo cromato, rivestimenti particolari, scelta di versioni fanno che quest'ampia gamma di sedute sia perfetta per l'ufficio-casa. Grazie alle sue varianti Auckland si adatta a più ambienti lavorativi: dall'ufficio operativo, a quello professionale, fino all'ufficio direzionale. Telaio in acciaio disponibile in due versioni: fisso o con razze a ruote piroettanti.

Office activities are easier, faster and more efficient thanks to new work technologies and systems. Auckland is a reliable, quick, efficient and versatile chair designed for modern offices. Chromed metal details, beautiful covers and a wide range of versions turn this collection into the ideal solution for homes and offices alike. All models are suitable for different work environments, from operational and professional offices to executive rooms. The steel frame is available either fixed or mounted on a base with castors.



## Auckland



Il mondo dell'ufficio guadagna maggiore leggerezza, efficienza, e duttilità grazie alle nuove tecnologie ed i nuovi sistemi di lavoro. Auckland è la sedia affidabile, veloce, efficiente e duttile per gli uffici di oggi. Dettagli in metallo cromato, rivestimenti particolari, scelta di versioni fanno che quest'ampia gamma di sedute sia perfetta sia per l'ufficio che per la casa. Grazie alle sue varianti Auckland si adatta a più ambienti lavorativi: dall'ufficio operativo a quello professionale, fino all'ufficio direzionale.

Office activities are easier, faster and more efficient thanks to new work technologies and systems. Auckland is a reliable, quick, efficient and versatile chair designed for modern offices. Chromed metal details, beautiful covers and a wide range of versions turn this collection into the ideal solution for homes and offices alike. All models are suitable for different work environments, from operational and professional offices to executive rooms. The steel frame is available either fixed or mounted on a base with castors.





## Venus

Una proposta in grado di assicurare una forte caratterizzazione dello spazio e che fa della semplicità e della razionalità i suoi principali valori. Ogni dettaglio è studiato in una soluzione compositiva caratterizzata da grande rigore e da massima funzionalità in una dimensione del confort che si declina all'insegna della versatilità.

The simple, rational style of this solution lends a distinctive touch to the room. Every single detail adds to the streamlined style of this chair, which blends outstanding functionality with comfort and versatility.







## Venus

Una elegante e contemporanea struttura in tubolare di acciaio cromato, leggera ed essenziale, si offre come supporto al sedile ed allo schienale prestandosi a molteplici usi e funzioni. Robuste ed ergonomiche, molto al di là delle apparenze, sono le sedute ideali per spazi giovani ed informali ma anche per arredare soluzioni d'arredo più importanti. Uno stile che vuole comunicare un'idea contemporanea della working area. Un'essenzialità di linee e volumi che predilige comodità e funzionalità, in cui il design convive con soluzioni contemporanee ed ergonomicamente avanzate.

The elegant, contemporary chrome steel tubes in the frame provide light, simple support for the seat and the backrest. The chairs are much more robust and ergonomic than they may appear and they are ideal for numerous uses and purposes, ranging from youthful, informal settings to more cultivated interior design schemes. The style aims to present a contemporary take on working areas. The essential lines and volumes promote comfort and practicality, as the designer look complements contemporary, ergonomically advanced solutions.





A volte l'aspetto estetico, l'insieme delle forme, il design, sono gli elementi che determinano la scelta di un oggetto.

Altre volte sono i contenuti tecnici ed ergonomici quelli che indirizzano, magari in modo più razionale, le nostre scelte. Di fronte a Artù non c'è invece alcun tipo di esitazione perchè ogni suo aspetto, sia tecnico che qualitativo estetico, è di livello eccezionale perchè ogni suo particolare è curato con la massima attenzione per offrire un prodotto confortevole e raffinato.

Il particolare bracciolo conferisce valore estetico ad una forma essenziale ma ricercata.

Sometimes the aesthetic aspect, the set of forms, the design, are the elements that determine the choice of an object. Other times are the technical and ergonomic characteristics those that, perhaps more rationally, affect our choices. Thinking of Artù, there is no any kind of hesitation because all its aspects, both technical, qualitative or aesthetic, are excellent and because every detail is treated with great care to offer a comfortable and high quality product.



## Artù



E' la seduta ideale per un ambiente di lavoro in cui l'attenzione per l'eleganza ed il rigore formale diventano importanti. Il design trova in questo oggetto una sua grande interpretazione: l'attenzione ai dettagli e alle finiture è ai massimi livelli. La preziosa trapuntatura della seduta prosegue sullo schienale, integrando in un tutt'uno la sua linea ricca e raffinata, creando un insieme molto particolare, esteticamente accattivante e di avanzata tecnologia. Nulla è lasciato al caso in questa seduta direzionale che unisce prestazioni e design in modo ottimale.

This is the perfect chair for working environments where a crucial part is played by a focus on formality and elegance. The dedication to details and finishing is taken to new heights in its remarkable design. The exquisite quilting runs all of the way from the seat to the top of the backrest, blending the rich, refined lines into one and creating a visually appealing and technologically advanced ensemble that is highly distinctive.

Nothing is left to chance in an executive chair that presents the ultimate blend of design and performance.





## Queen

Dimensionalmente ridotta,  
non perde nessuna delle  
caratteristiche della più grande  
Queen direzionale.

Una presenza di forte  
originalità e di grande impatto  
visivo, in grado di comunicare  
una sensazione immediata  
di confort. Tecnologia ed  
estetica si fondono in  
un'unica soluzione.

Despite its compact shape, this  
Queen model has the  
same distinguishing  
characteristics of its bigger.  
Its original style creates an  
unmistakable visual effect that  
conveys a feeling of  
comfort and sturdiness.  
Technology and visual appeal are  
combined in this beautiful model.



## Liz

Raffinato il disegno, curati i dettagli, selezionati i materiali; Liz è un modello prestigioso e dalla spiccata personalità, un classico dalla linea contemporanea in cui design, confort e funzionalità si fondono assieme in un equilibrio armonioso. Liz unisce il gusto e l'eleganza di un modello semplice e pulito, vagamente classico, interpretato in chiave attuale, con spirito leggero e moderno.

Un prodotto in divenire, aperto a diverse interpretazioni per progetti di ambienti non isolati o precostituiti, ma che interagiscono completandosi. Dall'immagine forte e di grande impatto visivo, diventa protagonista di qualsiasi ambiente.

Elegant design, fine details, selected materials; Liz is a prestigious model with a strong personality, a classic product with a contemporary line in which design, comfort and functionality are mixed together in a harmonious balance. Liz combines taste and elegance of a simply and clean model, classic, interpreted in an actual key, with light and modern spirit.

A product in development, open to different interpretations for project of spaces that are not isolated or pre-made, but that interact and complete themselves. With its powerful, striking image, it will take centre stage in any setting.







## Nest

Pura tecnologia e design futurista per questo modello dotato di una seduta importante e con prestazioni di confort a livello assoluto. Le più avanzate conoscenze tecnologiche e l'intelligente uso di materiali innovativi sono gli ingredienti fondamentali di questo modello caratterizzato da finiture in alluminio e dotato di meccanismi in grado di offrire prestazioni di qualità anche per momenti di lavoro prolungato.

Pure technology and futuristic design are the distinctive features of this model that blends outstanding performance with exceptional comfort. State-of-the-art technology and wise use of valuable materials are the basic ingredients of this model with a beautiful aluminium finish and innovative systems that deliver unrivalled performance even after prolonged use.





La ricerca di eleganza abbinata alla funzionalità della forma testimoniano lo spirito innovativo che sta alla base della filosofia progettuale. Prodotto innovativo e di grande confort, è realizzato utilizzando i migliori componenti e attento alle esigenze di un pubblico sempre più interessato al benessere personale, sia fisico che psichico. Da questa idea nasce questa famiglia di sedute, dinamiche e funzionali, concepite all'insegna della comodità.

Sophisticated elegance and functional shapes bear witness to the inventive spirit of our design philosophy. This innovative product is also particularly comfortable, and is made with the best components available in the market. It has been specifically designed for users who care for their physical and psychological wellbeing and has inspired a whole collection of dynamic, functional and above all comfortable chairs.





# Operative Office

area operativa





Lead





Poltrona operativa, caratterizzata dalla struttura in polipropilene antracite, schienale in rete oppure completamente rivestito, regolabile in altezza. Sedile in poliuretano espanso ad alta densità, rivestito. Meccanismo sincron. Base a 5 razze di nylon antracite con ruote gommata e autofrenanti. Optional: supporto lombare regolabile in altezza e profondità; appoggiatesta in rete; base alluminio; braccioli fissi o regolabili; traslatore.

Task chair, characterized by dark grey colour structure, with mesh backrest or completely upholstered, adjustable in height. Seat padded in high density polyurethane foam and upholstered. Synchron mechanism. 5-star dark grey nylon base on rubber and self-braking castors. Optional: lumbar support adjustable in height and depth; headrest in mesh; polished aluminium base; fixed or adjustable arms; slide system to adjust seat depth..



# Fit



Gli stimoli forti e continui in termini di ricerca tecnologica, soluzioni ingegneristiche e attenzione al valore estetico del prodotto hanno prodotto soluzioni contemporanee ed ergonomicamente avanzate.

In questo contesto è stata progettata Fit, la cui caratteristica è il bellissimo e innovativo schienale disponibile in varie versioni. Meccanismi di regolazione di altissima qualità, materiali e finiture al top di gamma, nulla è lasciato al caso in questa seduta operativa che unisce prestazioni e design.

Powerful, constant input in terms of technological research, engineering solutions and dedication to the visual appeal of products have resulted in contemporary, ergonomically advanced solutions. It was against this backdrop that Fit was designed.

Its distinguishing feature is its stunning, innovative backrest, which comes in a number of versions. The extremely high-quality adjustment mechanisms and top-of-the-range materials show that no detail was overlooked in this operative chair, which presents a peerless blend of performance and designer style.



## Fit



Diretta all'ufficio operativo,  
questa serie si caratterizza  
per la leggerezza delle sue  
forme e la solidità dei contenuti.

L'accostamento del leggero  
bracciolo con la solida struttura  
definisce l'aspetto più prezioso  
ed elegante del modello, oltre al  
fatto di soddisfare ogni esi-  
genza  
operativa mettendo sempre  
l'operatore a proprio agio.  
La seduta è regolabile in altezza  
ed inclinazione;  
anche il bracciolo è regolabile.

This line of desk chairs blends  
light weight with sturdiness.  
A solid frame with lightweight  
armrests is the distinguishing  
feature of this elegant model,  
which will meet any require-  
ments in terms of user comfort  
in the office.

Both the seat and the  
armrests are height adjustable.





Fit |





## Fit

Pura tecnologia e un design classico per questo modello dotato di importanti imbottiture che consentono prestazioni di confort assoluto. L'intelligente uso di materiali innovativi e moderni meccanismi offrono prestazioni di alta qualità anche per momenti di lavoro prolungato.

Pure technology and a classic design are the distinctive features of this model that blends outstanding performance with exceptional comfort; model with innovative systems that deliver unrivalled performance even after prolonged use.





## Fit up |

Fit Up è stata sviluppata con l'intento di soddisfare sia l'aspetto ergonomico che quello d'immagine, del sempre più attento ed esigente "mondo direzionale attivo". Nasce così un programma di poltrone caratterizzate da un design raffinato e da prestazioni ergonomiche eccellenti, in un contesto di tappezzeria preziosa e di finiture di altissimo pregio.

Fit Up has been designed both to satisfy the ergonomic needs and to meet with the pure aesthetical requirements of the mindful, demanding and "busy executive world".



## Fit up

Una proposta in grado di assicurare una forte caratterizzazione dello spazio e che fa della semplicità e della razionalità i suoi principali valori. Una sensazione unica di bellezza e di confort traspare da ogni particolare, studiato con la massima cura per ottenere un prodotto di straordinaria qualità. Ogni dettaglio è progettato in una soluzione compositiva caratterizzata da grande rigore e da massima funzionalità in una dimensione trasversale del confort.

Simplicity and rationality are the main values of this product, which can give a strong identity to its surroundings. A unique sense of beauty and comfort shines through in all of the details, which are planned with the greatest care to create a product of exceptionally high quality. Every single aspect plays a carefully considered part in an exacting and highly functional overall composition that spans the dimensions of comfort.



## Goal

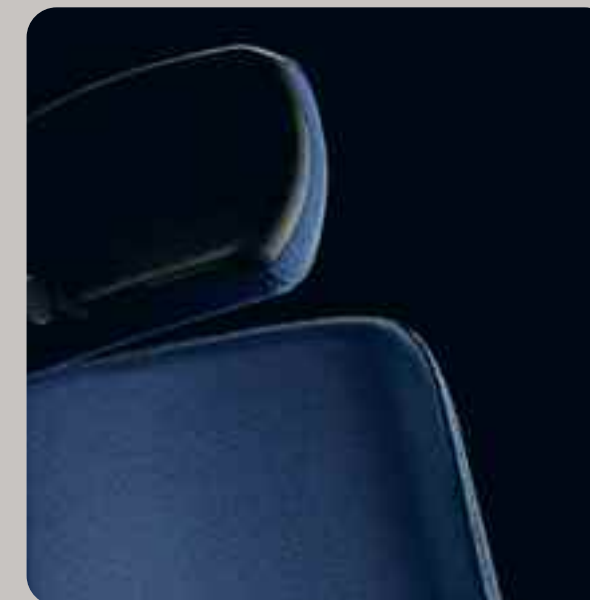

La seduta ergonomica e regolabile permette di ottenere la posizione più idonea alle proprie conformità fisiche. Diretta all'ufficio semidirezionale, Goal è la poltrona per chi desidera circondarsi di oggetti d'arredo di design, ma soprattutto confortevoli.

The ergonomic, adjustable seat can be moved into the most suitable position for any body shape. Goal is conceived for middle management offices and people who want to surround themselves with designer pieces that are also - and most importantly - comfortable.

## Goal



Le raffinate finiture, il particolare design del supporto schienale e il basamento lucido esaltano l'attualità di questo modello. Preziosi dettagli donano un notevole fashion appeal a questo modello direzionale; morbide imbottiture avvolgono la seduta per offrire un relax a tutto tondo, e le varie funzionalità degli innovativi meccanismi permettono di reinventare ogni giorno il proprio spazio lavorativo a seconda dell'uso che si desidera. Le forme attuali e la modernità dei materiali rendono il modello protagonista incontrastato di ambienti anticonformisti.

The refined finishing, the unique backrest design and the polished base highlight the contemporary nature of this executive model. Exquisite details add significant fashion appeal and soft padding envelops the seat for all-round relaxation. The different functions of the innovative mechanisms allow users to create new working environments to meet their changing needs on a daily basis. The contemporary forms and modern materials can make this model the undisputed star of unconventional settings.

## Goal

Lo schienale è dotato di una speciale rete in tessuto elasticizzata che cela un ergonomico supporto lombare, dettaglio creativo garante di funzionalità e confort. Il sedile, dotato di un innovativo poliuretano, consente a questo modello di essere la seduta ideale per un ambiente di lavoro in cui l'attenzione per l'eleganza ed il rigore formale diventano importanti. Il bracciolo chiuso rende ancora più compatta la linea della poltrona, oltre a garantirne un confort ideale anche per periodi di lavoro prolungati.

The special stretch fabric netting conceals an ergonomic lumbar support, in a creative feature that is both practical and comfortable. There is an innovative polyurethane in the seat of this product, which is the perfect solution for working environments where a crucial part is played by a focus on formality and elegance. The closed armrests make the silhouette of the chair even more compact, while offering the ideal level of comfort for even the longest working sessions.





## Flash

Flash è una collezione di sedute operative semi-direzionali, ideale per un ambiente di lavoro in cui attenzione per l'eleganza e rigore formale diventano importanti. Un equilibrio armonioso di tecnologia e design garantiscono un corretto confort, coadiuvato dal particolare sostegno sullo schienale in rete. Dalle linee pulite e minuziosa nei dettagli, è una seduta che non lascia nulla al caso.

This is the ideal chair for work environments where elegance and formal rigour are the key prerequisites. A harmonious combination of technology and design is synonymous with exceptional comfort, which is further enhanced by the special backrest. With clean lines and meticulous attention to details, this chair does not leave anything to chance.



## Flash

E' una poltrona caratterizzata dall'importante struttura dello schienale. La speciale rete in tessuto elasticizzato garantisce traspirabilità e confort. Il sedile è dotato di un innovativo poliuretano che offre prestazioni di qualità anche per momenti di lavoro prolungati. E' la seduta ideale per un ambiente di lavoro in cui attenzione per l'eleganza ed il rigore formale diventano importanti.

This chair is characterized by the prominent frame of the backrest. The special elastic mesh guarantees maximum comfort and breathability.

The seat features an innovative polyurethane which delivers unrivalled performance even after prolonged use. This is the ideal solution for work environments where elegance and formal rigour are the keywords.



Key



## Five



Five è stata sviluppata quale prodotto estremamente flessibile, dotato di numerose varianti formali. Il modello si distingue per un elevato grado di praticità, per l'accuratezza delle finiture e per le sue possibilità multiuso. Viene proposta con schienale alto e basso, e la collezione comprende anche la linea visitatore e lo sgabello operativo, ideale per arredare gli studi tecnici e gli ambienti professionali.



Five has been developed as an extremely flexible product, with many different models. It is characterized by a high level of practicality, by accuracy of the finishes and its multipurpose possibilities. It is available with high or low backrest, and the collection includes even visitor chair and the task stool, ideal for furnishing technical studios and professional environment.





## Free



## Free Mesh

Poltrona operativa, schienale in rete disponibile in 8 colori, con supporto lombare regolabile in altezza. Sedile in poliuretano espanso ad alta densità, rivestito. Meccanismo minisincron, che permette l'oscillazione dello schienale, bloccabile in 4 diverse posizioni, regolazione dell'intensità a seconda del peso dell'utilizzatore, dotato di meccanica antishock. Regolazione in altezza tramite pompa a gas. Base a 5 razze di nylon nero con ruote gommata e autofrenanti. Optional: base in alluminio, braccioli fissi o regolabili 3d.

Task chair, mesh backrest available in 8 different colors, with lumbar support adjustable in height. Seat padded in high density polyurethane foam and upholstered. Minisincron mechanism which allows only the movement of the backrest back and forward, blockable in 4 positions, antishock system and weight adjustment. Seat adjustable in height with gaslift. 5-star black nylon base on rubber and self-braking castors. Optional: polished aluminium base; fixed arms or 3d adjustable arms (height, depth, rotation).





## Dublino

La semplicità al servizio della funzionalità. Ergonomica, leggera, versatile e dal design attuale, è un'operativa di tecnologia avanzata disponibile con varie regolazioni. E' la sedia leggera, veloce, efficiente e duttile per l'ufficio moderno; grazie alle sue prestazioni si adatta a più ambienti lavorativi: dall'ufficio operativo, a quello professionale fino all'ufficio direzionale. I braccioli a "T" sono regolabili in altezza. La base girevole è in alluminio pressofuso lucido o in nylon nero.

Simple style at the service of functionality. Ergonomic, light, versatile and with a modern design, this model is a masterpiece of advanced technology and features different adjustment options. This light and flexible chair is ideal for modern offices, from operational and professional offices to executive rooms. The T-shaped armrests are height adjustable. The swivel base is made of die-cast aluminium with a glossy or in black nylon.



## Bingo

La forza della semplicità è tutta qui. Forme essenziali e pulite, misurate nelle proporzioni, ricercate nei dettagli in cui design, confort e praticità d'uso trovano un equilibrato punto d'incontro, offrendo la massima flessibilità per creare angoli di originale funzionalità e di facile inserimento in ogni tipologia d'arredo. Morbide imbottiture creano un rilassante guscio di confort che poggia su un pratico basamento a razze, nero o grigio. Una scelta agile, dinamica, in pieno stile contemporaneo.

The strengths of a simple style: clean shapes, balanced proportions, sophisticated details and a successful combination of design, elegance, comfort and ease of use are synonymous with outstanding flexibility and create original solutions that will suit any environment. Our padded models create a soft haven of comfort on black or grey base. These are dynamic solutions that suit modern lifestyles.



Community  
Spirit  
area collettiva



## Oxford



Questo è un innovativo programma polifunzionale per aule didattiche, concepito per soddisfare le pressanti esigenze di interattività tra insegnante e studenti.

Le molteplici varianti garantiscono possibilità combinatorie e modulari con effetti estetici e funzionali sempre diversi.

Oxford offre un ottimo livello ergonomico in un contesto di ingombro contenuto.

This is an innovative multi-purpose range for teaching rooms that has been designed to satisfy the huge need for interaction between teachers and students.

Countless visual and functional effects can be produced with modular arrangements and combinations of the many different versions. Oxford offers outstanding ergonomics while occupying little space.





## Aira

Il design trova in questo oggetto una sua grande interpretazione: l'elegante sinuosità della seduta, in netto contrasto con la rigidità della struttura, crea un insieme molto particolare, esteticamente accattivante e di avanzata tecnologia.

This chair is the epitome of outstanding design: the sinuous elegance of the seat contrasts with the rigorous style of the frame, creating a particularly beautiful visual effect enhanced by advanced technological details.



## Slim

Slim si adatta facilmente ad ogni tipo di ambiente grazie al suo design minimalista che abbina la struttura in tubo di acciaio cromato senza saldature al polipropilene della seduta e dello schienale disponibile in vari colori. Con o senza braccioli, con tavoletta o meno, Slim offre la libertà di scegliere la variante più adatta alle proprie esigenze.

Slim chairs fit in easily in any kind of surroundings thanks to their minimalist design, which combines a welding-free tubular chrome steel frame with a polypropylene seat and backrest in a range of colours. They are available with or without armrests and writing tablet and users can choose the models that best suit their needs.





## Slim



Una linea che è in grado di guardare al mondo dell'arredo in modo originale. La seducente struttura in tubolare di metallo suggerisce leggerezza e dona alla seduta una grande eleganza; disponibile sia con braccioli che senza, si adatta e valorizza gli ambienti informali e moderni. A questo si aggiunge l'attualità dei materiali che rendono Slim protagonista incontrastata di ambienti giovani e dinamici.

The line presents an original take on the furniture world. The enticing tubular metal frame imbues the chairs with a sense of lightness and great elegance. They are available with and without armrests and they complement and enhance informal and modern settings. In addition, the contemporary materials make Slim the undisputed star of young, dynamic environments.





## Slim



E' una seduta tutta da scoprire per il confort, la versatilità e la ricca scelta di opzioni. La sottile struttura è un guscio ergonomico, una comodissima seduta per riunioni o conferenze dotata di numerosi e utili accessori. Una proposta in grado di assicurare una forte caratterizzazione dello spazio e che fa della semplicità e della razionalità i suoi principali valori.

The comfort, versatility and wide range of options offered by this seating range are all waiting to be discovered. The slender structure is formed by an ergonomic shell. It is an extremely comfortable seating solution for meetings and conferences, with a large number of handy accessories. Simplicity and rationality are the main values of this product, which can give a strong identity to its surroundings.



## Slim

Sospesa grazie alla robusta struttura in metallo, anche su barra Slim non perde il suo carattere di seduta di elegante minimalismo. Grazie alla curvatura dello schienale è una sedia molto confortevole, anche per un lungo uso.

Si adatta perfettamente a sale d'attesa o di riunione dove è richiesto lo stile senza dimenticare la durabilità nel tempo.

The bar-mounted version of Slim has a sturdy metal frame that gives it a suspended appearance and preserves all of its elegant minimalism. Thanks to the curved backrest, the chairs are very comfortable, even when used for extended periods.

They are perfect for waiting and meeting rooms where both stylish looks and durability are required.



## Slim



Nella versione alta la seduta Slim guadagna in originalità ed eleganza. Leggero, slanciato, lo sgabello mantiene intatto il comfort di seduta, ampia e conformata per essere utilizzata da qualsiasi tipo di corporatura, anche massiccia. Utilissimo l'appoggiatesta realizzato con lo stesso tubo metallico della struttura portante.

The tall model from the Slim seating range is even more original and elegant. The seat of the light, slender stool is just as comfortable. It is wide and shaped to suit any body type, even larger figures. There is an extremely useful footrest made from the same tubular metal as the frame.

## Social

Social è la seduta visitatore disegnata per rispondere alle esigenze di chi cerca una sedia classica nelle forme ma con un stile contemporaneo, minimal ed elegante, adattabile a qualsiasi tipo d'ambiente. Oltre che elegante e resistente grazie alla struttura a slitta in tubo di acciaio, le imbottiture di sedile e schienale in poliuretano espanso sagomato rendono Social estremamente confortevole. E' la risposta alle esigenze degli spazi di attesa e meeting che abbina con semplicità la classicità del design al confort.

Social seating for visitors is designed to satisfy those who want chairs with classical forms and contemporary, minimal and elegant style that can suit any kind of setting. While the tubular steel sled frame is elegant and sturdy, the shaped polyurethane foam padding in the seat and backrest make Social extremely comfortable. With its simple blend of classic design and comfort, it caters perfectly to the needs of waiting and meeting rooms.





## Social

E' la sedia leggera, efficiente e duttile per gli uffici di oggi; Social è il classico per ogni situazione. Con la sua forma semplice è la risposta funzionale alle esigenze degli spazi di attesa, spazi collettivi e meeting abbinando la classicità del design al comfort. Dal design minimal, è variabile nella finitura dello schienale. La morbida imbottitura assemblata alla struttura della seduta può essere rivestita con tutti i tessuti del campionario, così da adattarsi a qualsiasi ambiente.

The light, efficient and flexible chairs are perfect for modern offices. Social is a classic for every situation. The simple shapes combine classic design and comfort to offer a functional response to the requirements of waiting areas, public spaces and meeting rooms. The design is minimal and a number of finishes are available for the backrest. The soft padding on the seat structure can be covered with any of the fabrics in our selection, so it can match any setting.





E' un modello di grande praticità e facilità d'uso, dal design attuale e dal confort ineccepibile. Il particolare schienale traforato conferisce valore estetico ad una forma essenziale ma ricercata.

Poco ingombrante ma egualmente comoda, coniuga estetica e funzionalità suggellate da uno stile essenziale.

Adatta per l'ambiente di lavoro, gli spazi di comunicazione, i luoghi conferenziali, l'ambiente domestico o il contract.

This model is extremely practical and easy to use, and its modern design is combined with exceptional comfort. The beautiful pierced back adds aesthetic value to an essential yet sophisticated style. Not too bulky but nonetheless particularly comfortable, this chair blends a beautiful essential style with functionality. It is suitable for working environments, conference rooms, homes and hotels alike.



Molto elegante nella versione bianca con struttura in metallo cromato, la poltroncina dimostra tutta la sua potenzialità funzionale nella disponibilità di utili accessori legati alle svariate esigenze lavorative.

L'utilissima tavoletta girevole agganciata al bracciolo, oltre a dar vita ad un accostamento gradevole dal punto di vista visivo, fornisce un comodo appoggio durante meeting o riunioni di lavoro.

This chair is particularly elegant in the white version with a chromed metal frame, and is also particularly functional because it can be completed with useful accessories. The useful slide-away tablet attached to the armrest not only looks good but is also particularly useful during meetings or conferences.



## Ice

Un prodotto "easy" in grado di dare vita, grazie ai vari colori disponibili, a qualsiasi ambiente ravvivandolo e donando un tocco di creatività. Facilmente posizionabile grazie ad un design pulito ed elegante, garantisce un buon grado di ergonomico benessere anche per un uso prolungato. E' inoltre facilmente impilabile e riponibile poi nell'apposito carrello dotato di ruote per essere facilmente spostato. E' disponibile totalmente in polipropilene o con sedile rivestito.

An "easy" solution that comes in so many colours that go well in any environments. Elegant design is combined with comfort and ergonomics. This chair is also easily stackable onto a dolly so that it can be easily moved to other rooms. It is available in polypropylene or with upholstered seat.



## Zeta



Semplicità ed eleganza che diventano contemporaneamente funzionalità e praticità. Per favorire il suo impiego, Zeta si apre e si chiude facilmente, in pochi istanti; nella posizione aperta è una comodissima seduta per riunioni, conferenze o zone attese, nella posizione chiusa diventa facile da stoccare grazie al ridotto ingombro, che ne facilita la movimentazione e il riuso successivo. Una seduta attuale e versatile per moderne sale conferenze.

Simplicity and elegance become simultaneously functionality and practicality. In order to facilitate its use, Zeta can be opened and closed easily, in few seconds. When it is open can be a very comfortable chair for conference, reception areas and community purposes, when it is closed, it is easy to store, thanks to its reduced dimensions, which facilitates handling and reuse. A versatile and modern chair for nowadays conference rooms.



## Zeta

Facile e funzionale. Così si presenta Zeta, seduta multifunzionale per eccellenza. Concepita per stimolare la creatività ed arricchire di nuove emozioni l'ambiente di lavoro, gli spazi di comunicazione, i luoghi conferenziali, l'ambiente domestico, o il contract. L'imbottitura assemblata alla struttura della seduta conferisce un ulteriore tocco di raffinata eleganza, mantenendo inalterata l'essenzialità del disegno. Al particolare bracciolo con appoggio sagomato può essere agganciata una funzionale tavoletta-scrittoio.

Simple and functional. This is Zeta, an excellent and clever multifunctional chair. Designed to stimulate creativity and to give new emotions to work environment, communication spaces, conference areas, home or contract places. The seat, padded and upholstered, together with the complete structure adds an extra touch of elegance, maintaining the simplicity of the design. Armrests of original design and a writing tablet with anti-panic system are available as optional.





## Sunny New



Facile e funzionale. Così si presenta Zeta, seduta multifunzionale per eccellenza. Concepita per stimolare la creatività ed arricchire di nuove emozioni l'ambiente di lavoro, gli spazi di comunicazione, i luoghi conferenziali, l'ambiente domestico, o il contract. L'imbottitura assemblata alla struttura della seduta conferisce un ulteriore tocco di raffinata eleganza, mantenendo inalterata l'essenzialità del disegno. Al particolare bracciolo con appoggio sagomato può essere agganciata una funzionale tavoletta-scrittoio.

Simple and functional. This is Zeta, an excellent and clever multifunctional chair. Designed to stimulate creativity and to give new emotions to work environment, communication spaces, conference areas, home or contract places. The seat, padded and upholstered, together with the complete structure adds an extra touch of elegance, maintaining the simplicity of the design. Armrests of original design and a writing tablet with anti-panic system are available as optional.





## Sunny New



Sobria e professionale nella versione verniciata nera, acquista un'immagine più leggera nella versione cromata. Lo schienalino è disponibile in varie versioni: in polipropilene bianco e nero; nei colori di campionario nella versione imbottita.

Clean and professional in the black varnished version, this chair is also available with a sophisticated chromed finish. The backrest comes in different versions: in polypropylene black or white.

This chair is available in our range of colours in the padded version.

## Bonn

Bonn è la proposta ideale per le zone accoglienza e contatto. Caratterizzata da una forma semplice ma innovativa, si distingue per un elevato grado di praticità, per l'accuratezza delle finiture e per le sue possibilità multiuso. Design, confort e funzionalità si fondono assieme nella linea semplice e contemporanea del modello, disponibile in versione in polipropilene o con seduta imbottita e rivestita nei tessuti di campionario.

Bonn is the perfect choice for reception and contact areas. Featuring a simple but innovative shape, it is characterized by a high standard of practicality, by accuracy of the finishes and its multipurpose possibilities. It is available with many optional, in order to be the best solution for both meeting and work moments and places. Design, comfort and functionality combine with simple and contemporary line of this model.



| Bonn

---



# new shapes of quality.

Lunga esperienza, proposte innovative e grande conoscenza dei materiali che, unitamente alle accurate lavorazioni, permettono di offrire prodotti garantiti per alta qualità e accurate finiture. Con attenzione all'evoluzione del design e della tecnologia, l'azienda risponde con prodotti realizzati a mano interamente in Italia e utilizzando materiali scelti con cura e non dannosi all'uomo e all'ambiente.

Long experience, innovative ideas and extensive knowledge of materials, together with the precise workmanship, can offer guaranteed high quality products and accurate details. Paying attention to the evolution of design and technology, the company responds with products manufactured entirely in Italy by hand and using materials carefully chosen and not harmful to humans and the environment.

Informazioni tecniche / Technical details

# Covering Fabrics

Tessuti / Rivestimenti

## Reti/Mesh

Auckland / Sunny



FB 0538

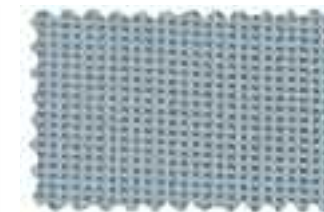

FG 0538



FN 0538

Flash/Goal/Nest/  
Social/Sunny/Lead



1001

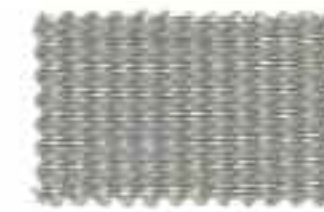

8043



8033



3029



4008



4016



7041



6501

Fit / Social / Slim



FB0538



FN0538

# Jet



Cat. F

# Planet

Cat. F



# Mirage



629



625



651



53



120



231



386



173



236



380



426



234



331



496



573

Cat. G

# Cube

Cat. G



2000



2003



2105



2007



2006



2005



2009



2008



2004



2017



2002



2011



2026



2028



2001



# Model



Cat. S

# Era

Cat. S



# Ikon



Cat. Top

# Blazer

Cat. Extra



## Pelle/Leather Fiesta



## Pelle/Leather Nuvola



## Pelle/Leather Polo

Cat. Fiesta



technical details  
caratteristiche tecniche

**Diemme Collection**



## Aira

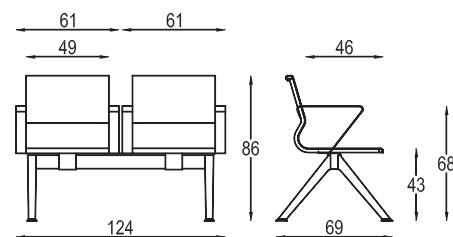

Panca in lamiera microforata, verniciata grigia, da 2, 3 o 4 posti. Ideale per zone attese, anche di spazi pubblici, come aeroporti. Scocca unica, con o senza braccioli. Optional: tavolino in lamiera.

Bench in metal structure, grey varnished finish, from 2 to 4 seats. Perfect for waiting areas, even of public spaces, as airports. Only shell, with or without arms. Optional: table.

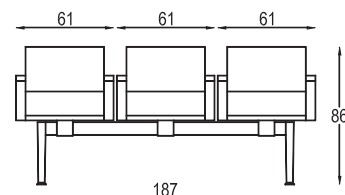

Banc en métal vernis gris, 2 - 3 - 4 places. Idéal pour les espaces publics comme les aéroports. Avec ou sans accoudoirs. Accessoire: table.

Bancada en metal, varnizada gris, de 2, 3, 4 asientos. Ideal para las zonas de espera, también para espacios públicos, como los aeropuertos. Carcasa única, con o sin brazos. Optional: mesa.

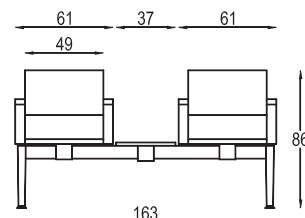
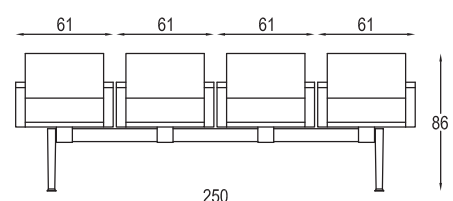

## Artù

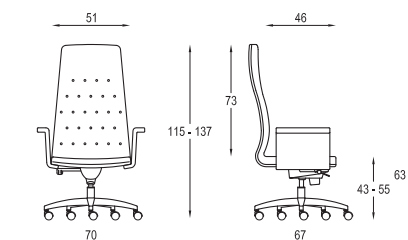

Executive and presidential office chair, shell in multilayer beech wood, padded in polyurethane foam. Gaslift or knee-tilt mechanism. 5-star in aluminium on rubber and self-braking castors. Fixed armrests padded and upholstered. Available even the visitor version with chromed cantilever frame and fixed arms.

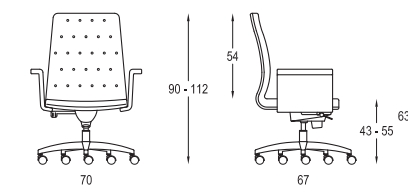

Sillon de directivos, respaldo medio o alto, estructura de madera de haya, acolchado de poliuretano. Mecanismo de gas o knee-tilt. Base a 5 radios de aluminio con ruedas engomadas. Brazos acolchados y tapizados. Disponible también en versión confidante con estructura cromada y brazos fijos.

Ligne de fauteuils de direction ou de présidence, caractérisés par une ligne classique et élégante. Coque en hêtre, rembourrée en polyuréthane. Disponibles avec mécanisme à gaz ou synchron; option d'accoudoirs rembourré. Base à 5 rayons en aluminium, sur roulettes. Disponible aussi en version visiteur avec luge chromé et accoudoirs fixes.

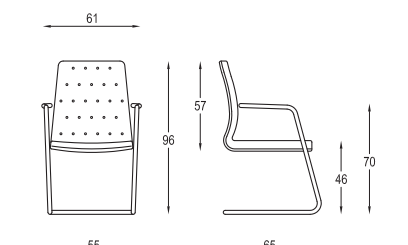

## Auckland

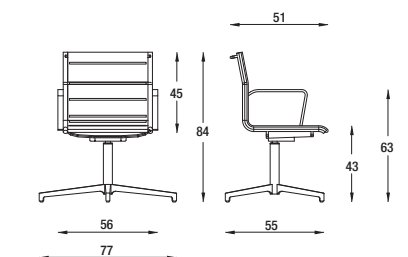

Stylish designed armchair for managers, executives and visitors; comfortable and strikingly versatile, perfectly suited to different working environment. Characterized by the grey, white or black mesh-net seat and back. Also available fully upholstered. Aluminium base and arms, gaslift or chromed sled frame or 4 aluminium blades frame.

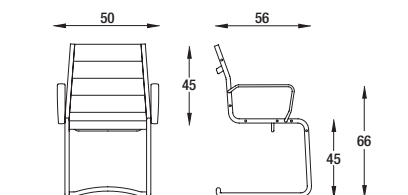

Sillón de diseño elegante para presidentes, directivos y visitantes; cómodo y muy versátil, perfecto para diferentes ambientes de trabajo. Caracterizado por un respaldo y un asiento de red negra, blanca o gris. Disponible también en versión todo revestida. Brazos y base de aluminio, elevación a gas o con base trineo cromada, o con base de 4 radios en aluminio.

Fauteuil de présidence, directionnel et visiteur avec un design raffiné, confortable et avec un prononcé éclectisme, parfaitement apte à plus pièce de travail. Caractérisée du dossier et siège en filet noir, blanc ou grise. Disponible aussi en version complètement revêtu. Accoudoirs et base en aluminium, élévation à gaz ou sur châssis glisse chromée ou avec base 4 rais en aluminium.

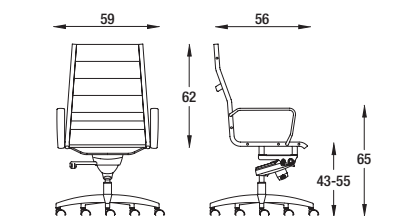
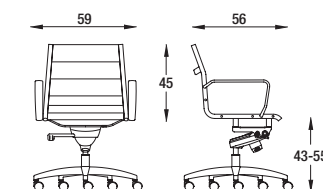

## Bingo

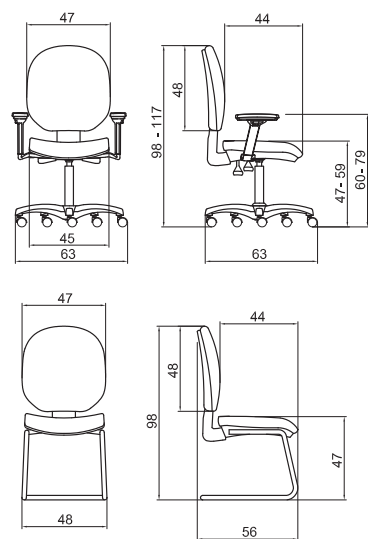

Sedia operativa, sedile e schienale in polipropilene nero o grigio, imbottitura in poliuretano espanso ad alta densità ed elastico. Supporto lombare integrato e regolabile in altezza grazie alla lama up&down. Meccanismo contatto permanente evoluto, con elevazione a gas e regolazione dello schienale in 4 diverse posizioni, dotato di meccanismo antishock e regolatore di tensione in base al peso corporeo dell'utilizzatore. Base a 5 razze in nylon nero o grigio o in alluminio pressofuso lucido, su ruote gommata e auto frenanti. I braccioli sono fissi in polipropilene neri o grigi, oppure regolabili in 3d (altezza, profondità e orientabili).

Siège opératif, structure en polypropylène noir ou gris, rembourré en polyuréthane élastique. Mécanisme contact permanent avec 2 réglages, pour le gaz et pour le mouvement de le dossier, avec antishock et réglementation de poids. La base et de polypropylène noir ou gris ou en aluminium avec roulettes pour seul dur. Les accoudoirs sont fixes grises ou noir ou réglables 3d.

Task chair, seat and back in grey or black polypropylene structure, padded in high density and elastic polyurethane foam. The mechanism is an advanced permanent contact, with 2 levers, one for the gaslift regulation and one for the oscillation of the backrest, lockable in 4 positions, with antishock mechanism and weight adjustment lever. The base is available in black or grey nylon, or in polished aluminium with rubber and self-braking castors. Fixed black or grey arms in polypropylene or adjustable 3d arms (height, rotation, depth).

Silla operativa, plasticos negros o grises acolchada de poliuretano de alta densidad y elastico. Mecanismo contacto permanente avanzado, con 2 regulaciones, una para el gas y otra para el movimiento del respaldo bloqueable en 4 diferentes posiciones, con antishock y regulacion de peso. La base es disponible en negro, gris o aluminio con ruedas engomadas. Brazos fijos negros o grises o ajustables 3d.

## Bonn

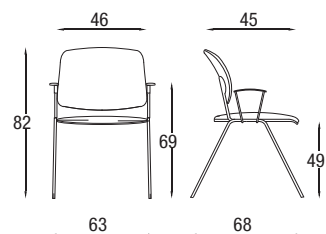

Sedia impilabile multiuso con o senza braccioli disponibile anche nella versione su barra da 2 a 5 posti, corredata da vari e funzionali accessori, (tavola per scrittura, cestello sottosedile, piani d'appoggio). Seduta e schienali possono essere imbottiti in poliuretano espanso, in legno di faggio o in polipropilene. Il telaio a 4 gambe ed i braccioli possono essere verniciati nero o cromati.

Chaise empilable avec ou sans accoudoir, disponible également dans la version sur barre de 2 à 5 places équipée de différents accessoires (tablette écrite, panier sous le siège, plan d'appui). Le siège et le dossier sont rembourrés en polyuréthane expansé; aussi disponible dans la version en bois au polypropylène. La structure et les accoudoirs peuvent être vernis en noir ou chromé.

Stackable chair with and without armrest, also available in a bench from 2 to 5 seater, with different optional (writing tablet, trolley and tray). The seat and backrest are padded and upholstered, or they are available even in wood and polypropylene. The 4 legs frame and armrests are either varnished black or chromed.

Silla apilable, con o sin brazos, disponible también en la versión de barra de 2 a 5 asientos. Con diferentes opcional: mesa de escritorio, llano de apoyo, cesta bajo del asiento. El asiento y el respaldo pueden ser acolchados en poliuretano o de madera de haya o en polipropileno. La estructura de 4 patas y los brazos pueden ser barnizados negros o cromados.

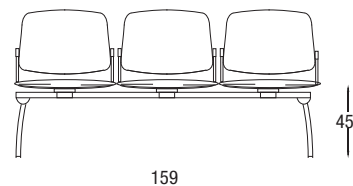

## Bread

Divano modulare, 1,2 e 3 posti, e disponibile in una serie di elementi adatti anche per composizioni di diversa forma, interni in legno e imbottitura in poliuretano espanso. Struttura in acciaio verniciato bianco e piedini in rovere.

Canapé modulaire 1, 2 et 3 places et éléments pour composer des allures différents. Structure de bois, mousse de polyuréthane. Structure de acier vernisé blanc et pieds en chêne.

Modular sofa, 1, 2 or 3-seater sofa, and available in different elements to create many shapes, inner in wood and padding in polyurethane foam. Structure in metal white varnished and feet in oak.

Sofa modular, butaca y 2 o 3 asientos, y elementos que se pueden acostar para configurar diferentes formas. Estructura interior de madera, acolchado de poliuretano. Estructura de acero barnizado blanco y pies de roble

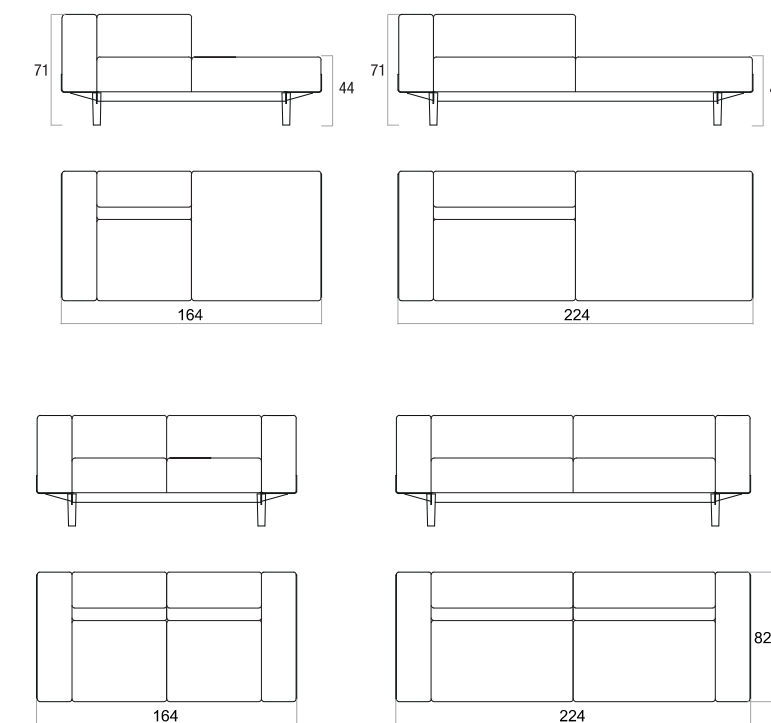
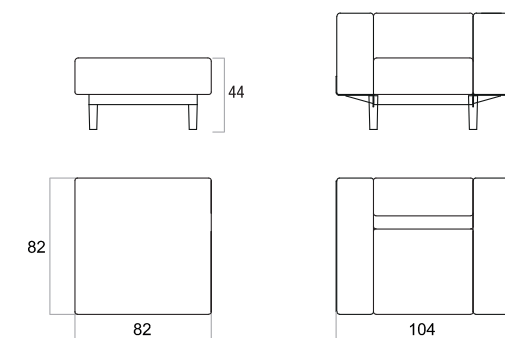

## Bread tavoli

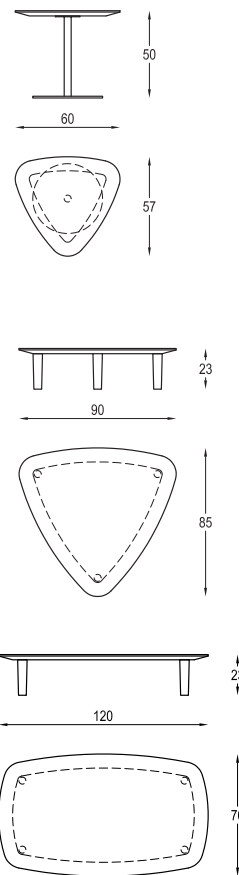

Tavolo da attesa, disponibile in 3 varianti: top rettangolare in mdf colore bianco, antracite o rovere su piedi in rovere naturale o verniciati bianchi h 23 cm; top triangolare grande in mdf bianco o antracite su piedini in rovere naturale o verniciati bianchi h 23 cm; top triangolare piccolo in mdf bianco o antracite su basamento cromato tondo h 50 cm.

Tables bas pour salle d'attente, disponible en 3 variants: plateau rectangulaire en mdf laqué blanc ou gris sur pies de bois ou verni blanc h 23 cm; plateau triangulaire en mdf laqué blanc ou gris sur pies de bois ou verni blanc h 23 cm; plateau petit triangulaire en mdf laqué blanc ou gris sur piedement chromé, h 50 cm.

Coffee table for waiting areas, available in 3 versions.: rectangular shape top in mdf lacquered white, dark grey or oak, on feet in natural oak or white varnished h 23 cm; triangular shape top in mdf lacquered white or dark grey on feet in natural oak or white varnished h 23 cm; small triangular top in mdf lacquered white or dark grey on chromed round base, h 50 cm.

Mesitas para salas de esperas de 3 tipologias: tope de mdf lacado blanco o negro o roble con pies de roble natural ou vernizado blanco h 23 cm; tope triangular de mdf lacado blanco o negro o roble con pies de roble natural ou vernizado blanco h 23 cm; tope triangular pequeno con base cromada h 50 cm.

Un concetto dalle infinite possibilità. Interni in legno e imbottitura in poliuretano espanso. Comprende la poltrona, il divano due posti e una serie di elementi di varie dimensioni e altezze, lineari o curvi, che uniti tra loro formano composizioni originali adatte ad ogni tipo di spazio e layout.

Un concept de possibilités infinies. Structure en bois rembourrée en mousse polyuréthane. Disponible la fauteuil, le canapé deux places et un certain nombre d'éléments de différentes mesures et hauteurs, droites ou courbes, à utiliser pour former des compositions originales adaptées à tous les types d'espace et disposition.

A concept of countless configurations. Inner in wood and padding in polyurethane foam. It includes the armchair, the two-seater settee, and a series of variously sized curved and straight elements which can be linked up together to form original layouts suited to every type of workspace and waiting area.

Un concepto de posibilidades infinitas. Composicion de madera y acolchado de poliuretano. Disponible la butaca, el sofa 2 asientos y una serie de diferentes elementos curvos o lineares que puestos juntos crean composiciones originales para cualquier tipo de espacio y lugar.

## Circuit

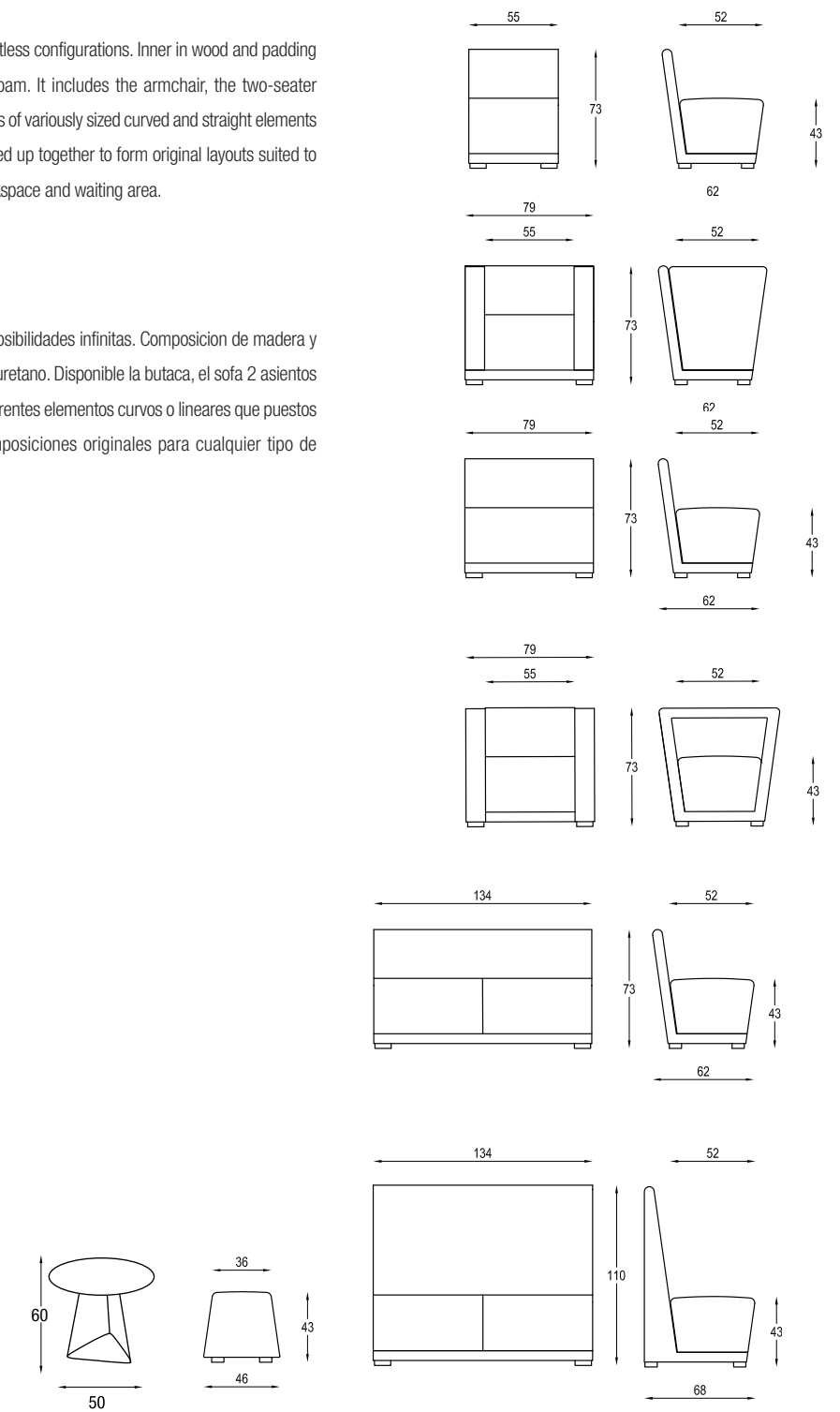

## Circuit privé

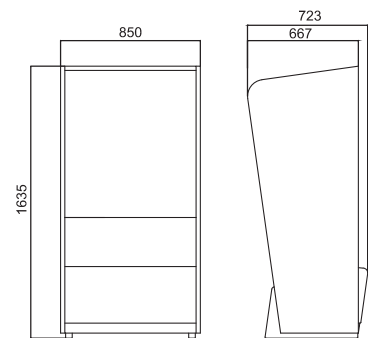

Divano a due posti e poltrona con schienale alto, dalle linee moderne, adatte ad una soluzione che richiede privacy. Interni in legno e imbottitura in poliuretano espanso. Piedini in rovere naturale.

2-seater sofa and armchair, with high backrest, characterized by modern shapes and suitable for an environment that requires privacy. Inner in wood and padding in polyurethane foam. Feet in oak, natural varnished.

Canapé 2 places et fauteuil avec dossier haut, parfait pour des espaces où la privacy c'est important. Structure intérieure avec bois et rembourrage en polyuréthane. Piés de chêne, vernis naturel.

Sofa 2 asientos y butaca con respaldo alto, caracterizada por líneas modernas y perfectas para un entorno que necesita de privacy. Interior de madera y acolchado de poliuretano expandido. Pies de roble, varnizados natural.

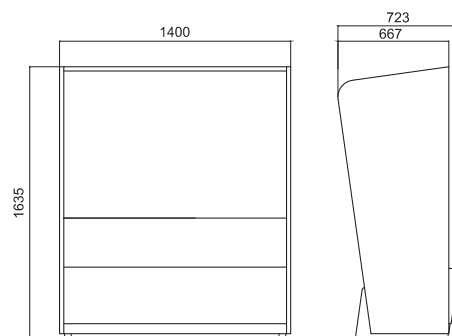

## Clea

Seduta dalla linea sinuosa, con struttura interna in acciaio e imbottitura in poliuretano schiumato a freddo. Disponibile su vari basamenti: base girevole 5 razze in alluminio con alzata gas su ruote gommate, base 4 lame in alluminio con meccanismo di ritorno automatico, base girevole a 4 razze in tubolare di acciaio, base slitta cromata o base piramidale in alluminio verniciata bianca o antracite. Con o senza braccioli tubolari cromati. Disponibile anche la versione panca 2, 3, 4 o 5 posti, perfetta per sale d'attesa.

Petit fauteuil caractérisé par une ligne sinueuse, avec structure en acier et rembourrage en mousse de polyuréthane à froid. Disponible avec différents types de piétements: 4 rayons tubulaires pivotante en acier chromé, 5 rayons sur roulettes avec réglage hauteur gaz, 4 rayons en aluminium avec mécanisme de retour automatique, luge chromé et pyramidale en aluminium peinté blanc ou gris foncé. Avec ou sans accoudoirs tubulaires chromés. Aussi disponible en version banquette 2, 3, 4 ou 5 places, parfaite pour salles d'attente.

Armchair characterized by sinuous line, with steel interior and cold-foamed polyurethane padding. Available with different types of legs/bases: swivel base in chromed steel, 5-stars aluminum base on self-braking rubber castors with gaslift, 4-blades aluminium base with self-return mechanism, sled chromed base or aluminium pyramidal base painted white or dark grey. With or without chromed tubular armrests. Also available on bench version for 2, 3, 4 or 5 seaters, perfect for waiting areas.

Butaca caracterizada por una línea sinuosa, con estructura de acero y acolchado de poliuretano espumado en frío. Disponibles con diferentes tipos de estructuras: giratoria de acero cromado, 5 radios de aluminio pulido con ruedas engomadas y elevador de gas, base de aluminio 4 radios con mecanismo de auto-retorno, base trineo cromada o piramidal giratoria de aluminio pintado de blanco o antracita. Con o sin apoyabrazos tubulares cromados. Disponible también en la versión banco de 2, 3, 4 o 5 asientos, perfecto para salas de espera.

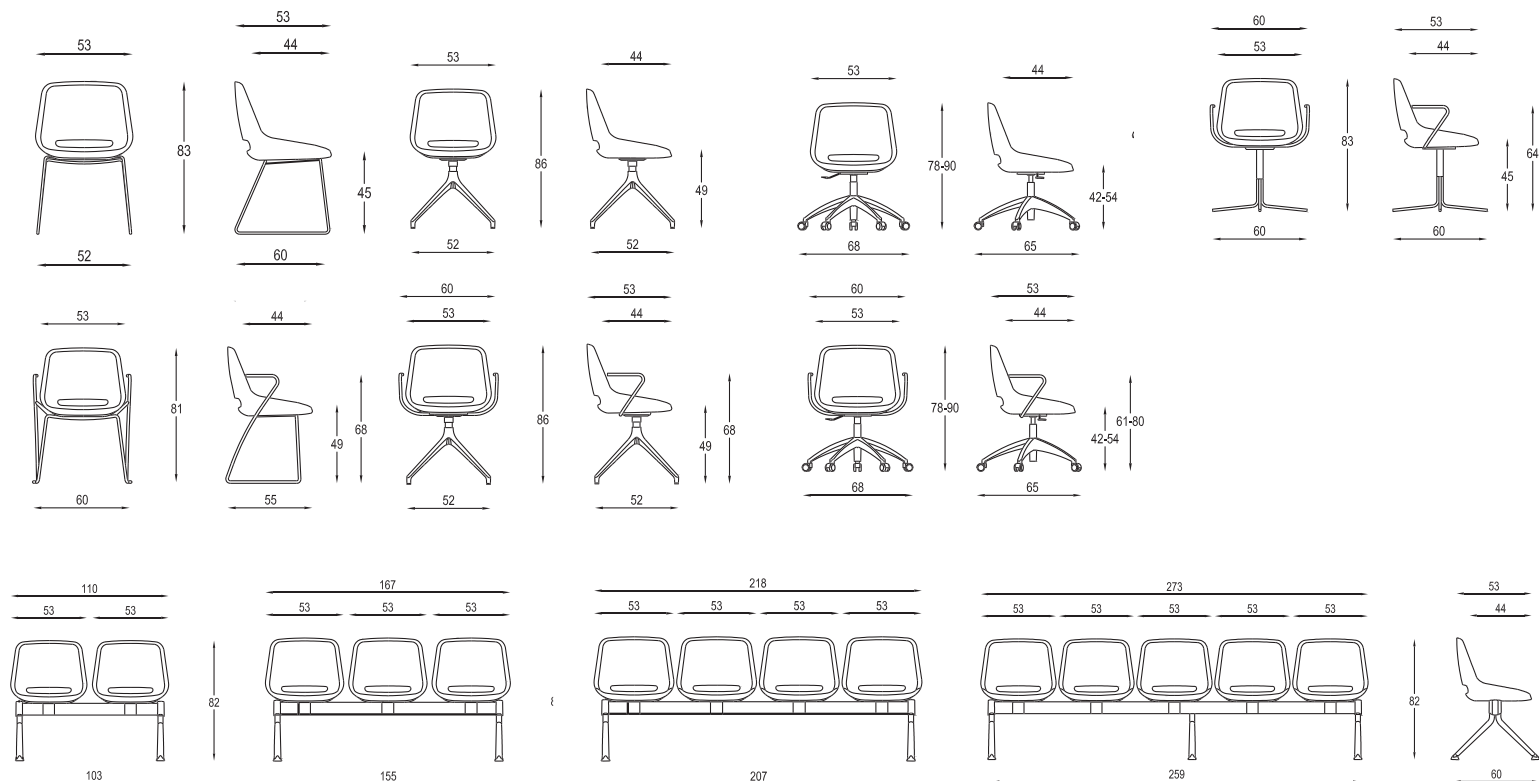



## Clea plus

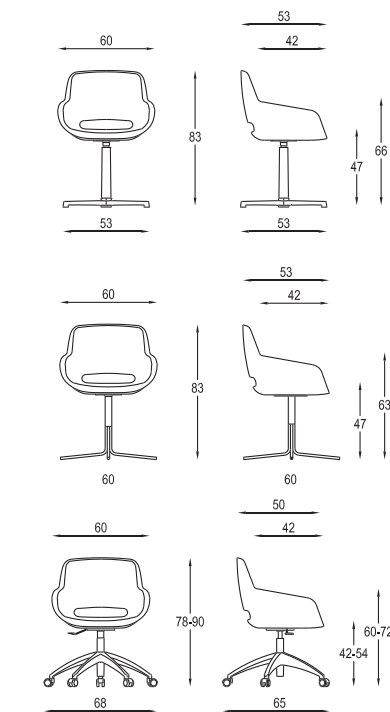

Poltroncina dalla linea sinuosa, con struttura interna in acciaio e imbottitura in poliuretano schiumato a freddo. Disponibile su vari basamenti: base girevole 5 razze in acciaio con alzata gas su ruote gommate, base 4 lame in alluminio con meccanismo di ritorno automatico, base girevole a 4 razze in tubolare di alluminio, base slitta cromata o base piramidale in alluminio verniciata bianca o antracite.

Petit fauteuil caractérisé par une ligne sinueuse, avec structure en acier et rembourrage en mousse de polyuréthane à froid. Disponible avec différents types des piétements: 4 rayons tubulaires pivotante en acier chromé, 5 rayons aluminium sur roulettes avec réglage hauteur gaz, 4 rayons en aluminium avec mécanisme de retour automatique, luge chromé et pyramidale en aluminium peint blanc ou gris foncé.

Armchair characterized of sinuous line, with steel interior and cold-foamed polyurethane padding. Available with different types of legs/bases: swivel base in chromed steel, 5-stars aluminum base on self-braking rubber castors with gaslift, 4-blades aluminium base with self-return mechanism, sled chromed base or aluminium pyramidal base painted white or dark grey.

Butaca caracterizada por una línea sinuosa, con interior de acero y acolchado de poliuretano espumado en frío. Disponibles con diferentes tipos de estructuras: giratoriade acero cromado, 5 radios de aluminio pulido con ruedas engomadas y elevador de gas, base de aluminio 4 radios con mecanismo de auto-retorno, base trineo cromada o piramidal giratoria de aluminio pintado de blanco o antracita.

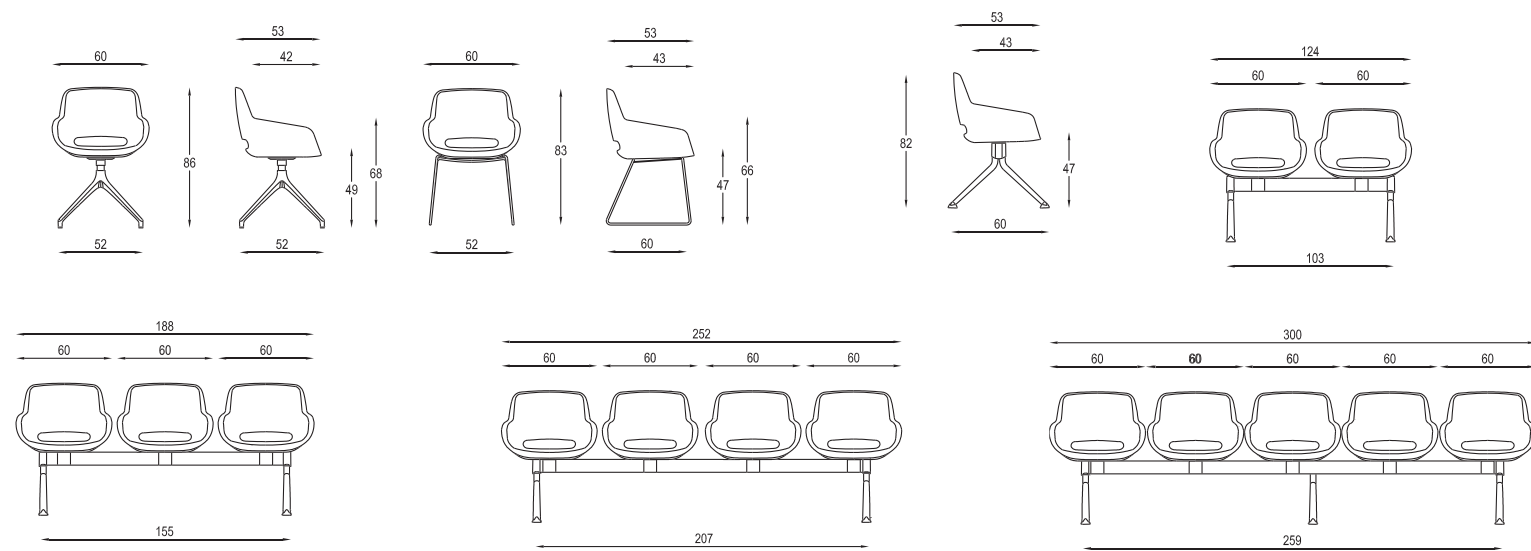

## Clock

Tavolino da attesa, in acciaio verniciato bianco o antracite. Altezza 68 cm.

Coffee table, in steel white or dark grey varnished. Height 68 cm.

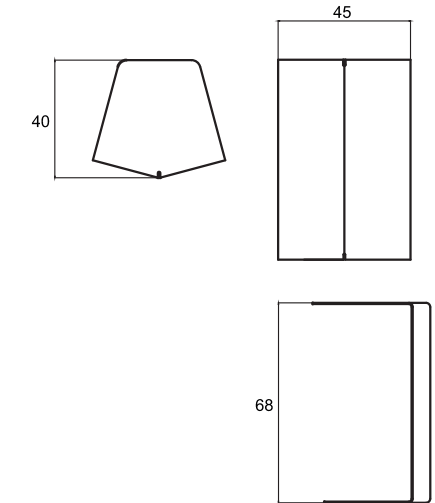

Tables bas pour salle d'attente, en acier verni blanc ou gris foncé. H 68 cm.

Mesita, en acero varnizado blanco o gris oscuro. H 68 cm.

## Cross

Divano componibile, dalla forma elegante e originale. Struttura interna in legno e imbottitura in poliuretano espanso ad alta densità.

Modular sofa, with an original and design. Structure in multilayer beech wood and padded in polyurethane foam.

Canapé modulaire, à la forme original et élégante. Structure en multiplis et bois aggloméré recouvert d'une mousse indéformable de polyuréthane et doublée de fibres de polyester.

Sofà modular, de forma elegante y original. Estructura de haya y acolchado con poliuretano de alta densidad.

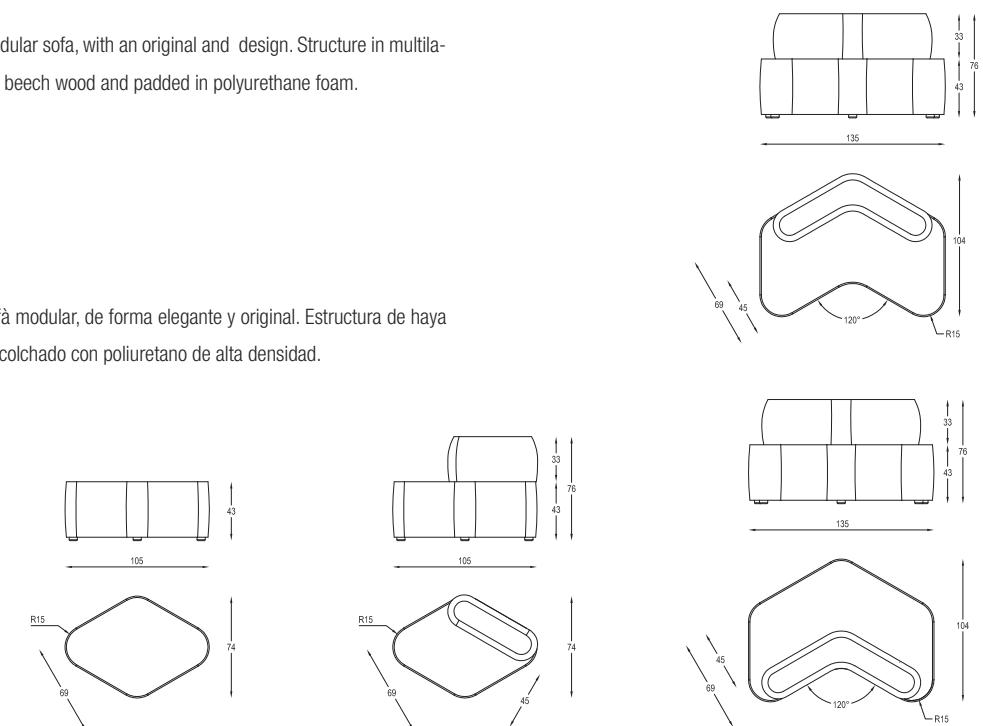

## Dama

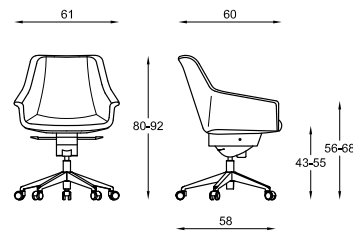

Poltroncina, interno in acciaio e imbottitura in schiumato a freddo. Disponibile con base girevole con alzata a gas, 5 razze in alluminio su ruote gommatae, base 4 lame in alluminio con meccanismo di ritorno automatico in posizione, base fissa 4 gambe in frassino naturale, base slitta cromata o base girevole in alluminio verniciata bianca o antracite.

Armchair, inner in steel and padding in injected foam. Available with 5-star polish aluminium base, on rubber castors, on 4 blades aluminium frame with return mechanism, on fixed 4 legs in ash finish, on chromed sled frame or in aluminium white or dark grey varnished swivel frame.

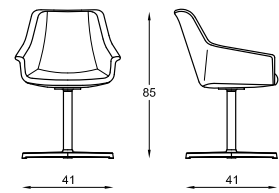

Petit fauteuil, coque en acier avec rembourrage de polyurethane a froid. Disponible avec pietment 5 rayons sur roulettes avec gaz ou pietment en aluminium 4 pies avec retour automatique, avec 4 pieds en cendre fixes, ou trineau chromé ou avec 4 rayons en aluminium verni blanc ou gris foncé.

Butaca, carcasa de acero y acolchada de poliuretano a frio. Disponible con base 5 radios de aluminio con ruedas y subida a gas, o con base de 4 radios de aluminio con retorno automatico, o con pies fijos de ceniza o con patin cromado o con base de 4 radios giratoria de aluminio barnizado blanco o antracita.

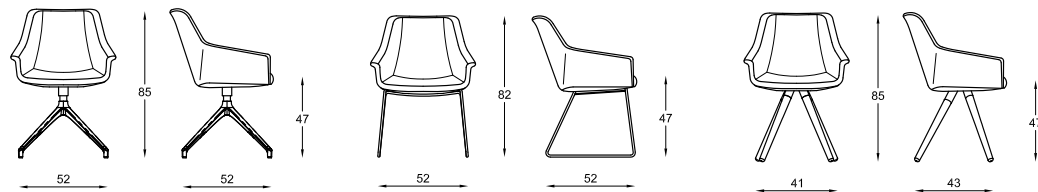

## Dama

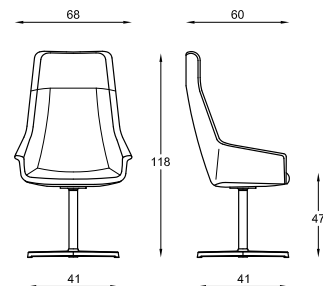

Poltrona presidenziale, schienale alto, interno in acciaio e imbottitura in schiumato a freddo. Base girevole con alzata a gas, 5 razze in alluminio su ruote gommatae o con meccanismo knee-tilt. Optional: appoggiatesta. Disponibile anche in versione lounge con 4 razze in alluminio e meccanismo di ritorno in posizione.

Executive armchair, high backrest, inner in steel and padding in injected foam. Swivel base, on 5-star polish aluminium base, on rubber castors with gas or knee-tilt mechanism. Optional: headrest. Available even the lounge version with 4 blades aluminium frame with return mechanism.

Fauteuil de direction, dossier haut, coque en acier avec rembourrage de polyurethane a froid. Pietment 5 rayons sur roulettes avec gaz ou avec mecanisme tilt. Optional: tetiere. Disponible la version lounge avec 4 rayons en aluminium et retour automatique.

Silla ejecutiva con respaldo alto, carcasa de acero y acolchada de poliuretano a frio. Base 5 radios de aluminio con ruedas y subida a gas o mecanismo tilt. Optional: reposacabeza. Disponible version lounge con base 4 radios de aluminio con mecanismo de retorno en posicion.

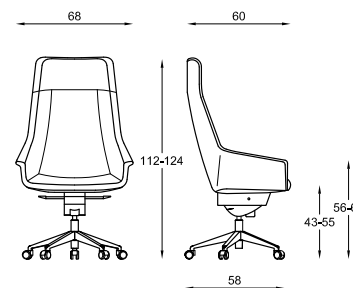

## Double

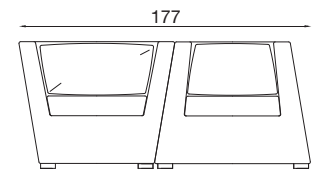

Poltrone dalla forma elegante, caratterizzate da una perfetta linea di aderenza per l'accostamento l'una con l'altra. Con struttura in multistrato di legno imbottito in poliuretano espanso. Piedini in alluminio lucido. Disponibile anche divanetto 2 posti.

Snugly interlocking elegant armchairs with structure in multilayer beech wood, padded in polyurethane foam. Aluminium feet. Available also as two-seater sofa.

Fauteuil à la forme élégante, caractérisée d'une parfaite ligne d'adhérence pour le rapprochement l'une avec l'autre. La structure est en hêtre multi-couche recouvert de polyuréthane expansé. Petits pieds en aluminium brillant moulé sous pression. Aussi disponible le canapé 2 places.

Sillón de la forma elegante, caracterizados por una línea perfecta procedente del acercamiento de los mismos. Con estructura en multistrato de madera revestido por poliuretano esponjoso. Pies en aluminio lustre. Disponible también el sofá con doble asiento.

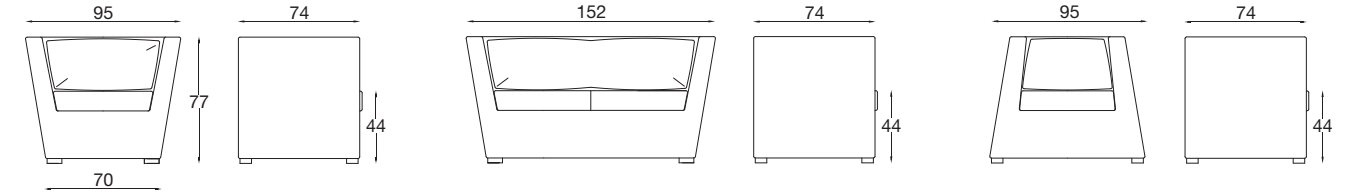
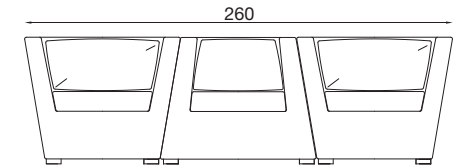

## Dublino

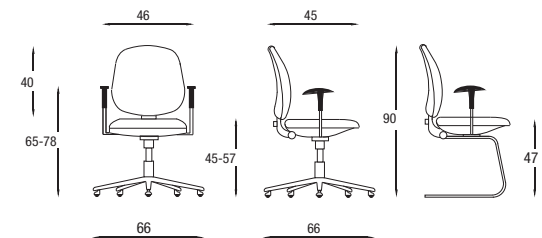

Serie di sedute dattilo con schienale alto o basso, comunque oscillante, regolabile in altezza e bloccabile in qualsiasi posizione. Disponibile nelle versioni ad elevazione gas con contatto permanente, con meccanismo sincronizzato di oscillazione oppure a slitta verniciata nero con contatto permanente. E' caratterizzato da due tipi di bracciolo: fisso in nylon nero, regolabile in altezza ed orientabile in nylon nero. Disponibile anche nella versione sgabello.

Range of chairs for typists with tall and low backrest, all oscillating, and with adjustable height; they may be fixed in any position. Available with gas height adjustment mechanism with permanent contact, synchronized mechanism or black varnished cantilever frame with permanent contact. The chair comes with two types of armrests: fixed in black nylon or height-adjustable and swivelling in black nylon. Also available in stool version.

Série de sièges dactylo avec dossier haut ou bas bas, oscillant, réglable en hauteur, ils peuvent être bloqués dans n'importe quelle position. Disponibles dans les versions à élévation à gaz avec contact permanent, ou avec un mouvement synchon, ou bien à coulisse vernie en noir avec contact permanent. Ils sont caractérisés par deux types d'accoudoir: fixe en nylon noir, réglable en hauteur en nylon noir. Egalement disponible en version tabouret.

Serie de sillas dactilo con respaldo alto o bajo, en todo caso oscilante, ajustable en altura y bloqueable en cualquiera posición. Disponible en las versiones a elevación gas con contacto permanente, con mecanismo sincronizado de oscilación o bien a trineo barnizado negro con contacto permanente. Es caracterizado por dos tipos de brazo: fijo de nylon negro, ajustable en altura y orientable de nylon negro. Disponible también en la versión taburete.

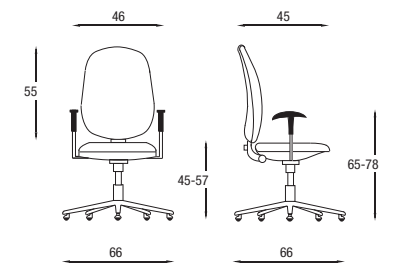

## Duke

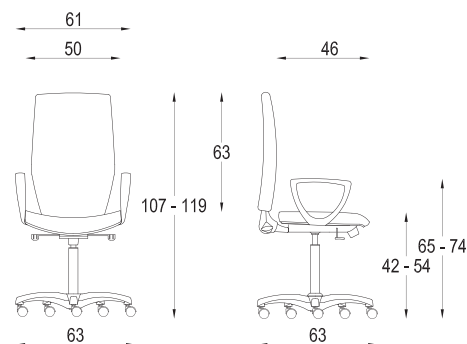
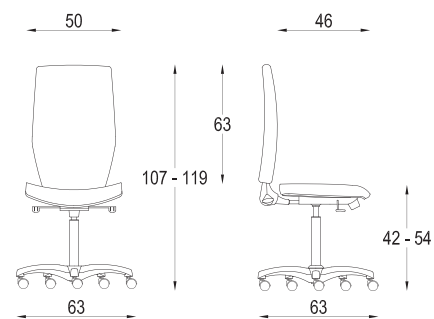
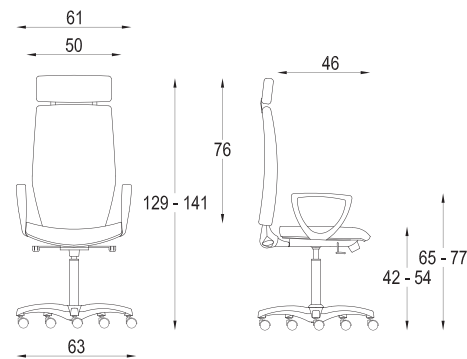
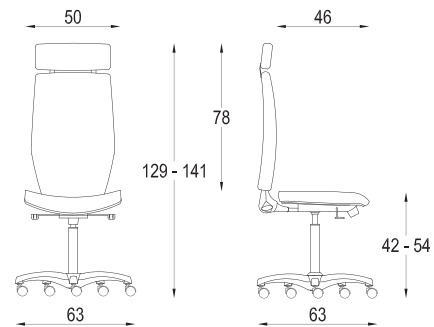

Poltrona direzionale, con schienale medio o con appoggiatesta, caratterizzata dalle linee eleganti e dal massimo comfort. Scocca in multistrato di faggio, imbottita in poliuretano espanso. Meccanismo sincron, con base 5 razze in nylon nera o in alluminio, su ruote autofrenanti e gommate. Optional: 4 tipi di braccioli: in polipropilene fissi bianchi o neri, fissi in poliuretano nero, regolabili in polipropilene nero.

Fauteuil de direction ou de présidence, caractérisés par une ligne classique et élégante. Coque en hêtre, rembourré en polyuréthane. Disponibles avec mécanisme synchron; option des accoudoirs fixes en nylon noir ou blanc, en polyuréthane noir ou réglables. Base à 5 rayons en nylon noir ou aluminium, sur roulettes.

Executive armchair, extremely comfortable, with medium backrest or headrest. Multilayer beech wood shell, padded in polyurethane foam. Synchronized mechanism on 5 star black nylon base or aluminium, on rubber castors. Optional: 4 kind of armrests: fixed, in polypropylene black or white, fixed in black polyurethane, adjustable in polypropylene.

Sillon directivo, caracterizado por una linea elegante y ergonomica. Respaldo medio o con reposacabeza. Estructura de madera de haya y acolchada. Mecanismo sincronizado, con base 5 radios negra o de aluminio con ruedas engomadas. 4 tipologias de brazos, fijos de polipropileno negro o blanco, fijos de poliuretano negro, ajustables de polipropileno.

Sedia ideale per il mondo contract, ufficio e per il settore casa. Scocca in poliuretano rigido TECH, colorato. Disponibile su telaio 4 gambe cromato, su telaio slitta cromato, su gas e base a 5 razze in alluminio con ruote o su telaio girevole in tubolare d'acciaio. Versione su panca da 2 / 3 / 4 posti. Sgabello fisso con telaio cromato o con gas e base rotonda cromata. La scocca può essere anche imbottita e rivestita.

Chaise pour la maison et le bureau. Coque de polyuréthane rigide TECH, de couleur. Disponible avec piétement à 4 pieds chromé, avec châssis glisse chromé, avec gaz et 5 rais d'aluminium sur roulettes. Eon est conçue même pour les bancs, de 2 à 4 places, et le tabouret sur base fixe ou gaz. La coque peut être rembourré et tapissé.

Chair perfect for contract, home and office areas. Shell in rigid TECH polyurethane, colored. Available with 4 chromed legs frame, with cantilever frame, with gaslift and 5 star aluminium base on castors and 4 star tubular swivel frame. Eon is conceived even for benches, from 2 to 4 places, and stool on fixed or gaslift base. The shell can be padded and upholstered.

Silla, ideal por el sector contract, el hogar y la oficina. Estructura de poliuretano rigido TECH colorado. Disponible con 4 patas cromadas, patin cromado, con elevacion a gas y base a 5 radios de aluminio fundido y ruedas o con base en tubular de acero cromado, giratoria. Eon sale también como bancada de 2 a 4 asientos y como taburete a gas o fijo, con estructura cromada. La silla puede ser acolchada y tapizada.

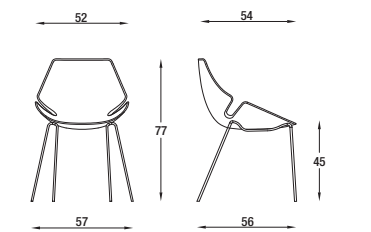
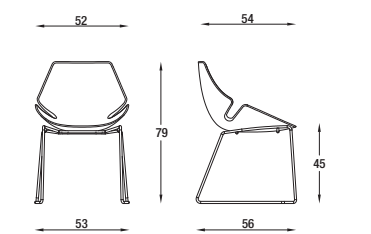
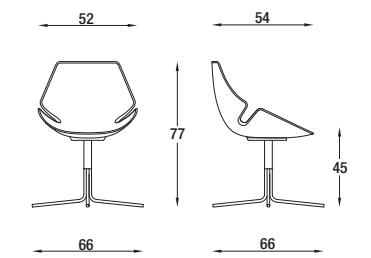
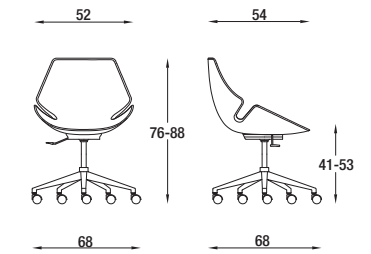
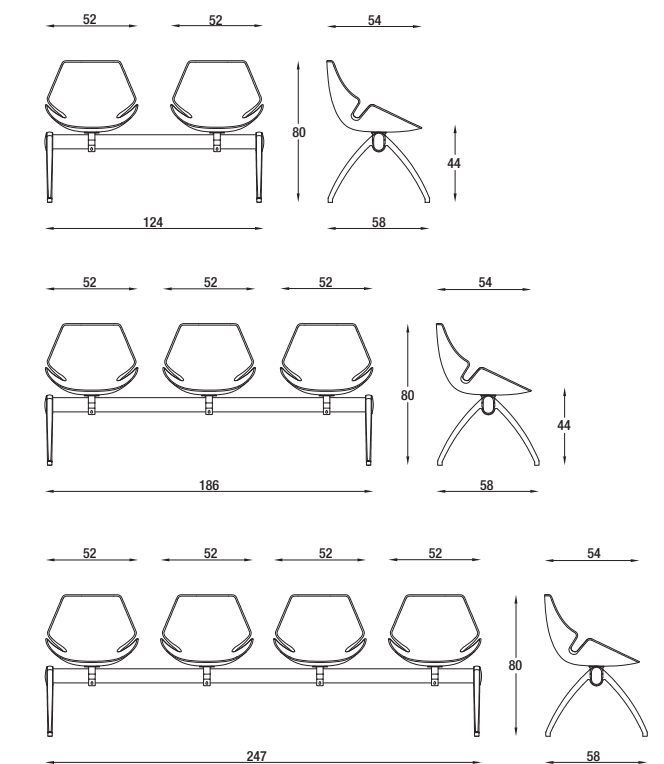
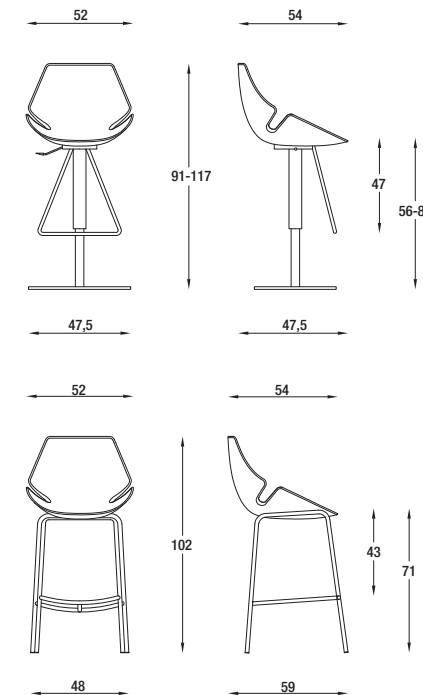

## Eon

## Fit/Fit up

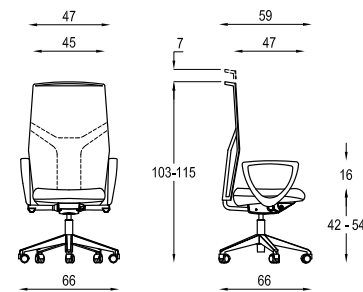

Sedia operativa, schienale in rete bianca o nera o in polipropilene bianco o nero o rivestito, regolabile in altezza. Sedile imbottito in poliuretano espanso elastico e completamente rivestito. Meccanismo synchron. Base a 5 razze in nylon bianca o nera o in alluminio, su ruote gommata. Braccioli fissi o regolabili. Optional: appoggiatesta.

Task chair, backrest in white or black mesh or in white or black polypropylene, or completely padded adjustable in height. Seat padded in elastic polyurethane foam. Synchron mechanism. White or black nylon base or in polish aluminium on rubber and self-braking castors. Fixed or adjustable arms. Optional: headrest.

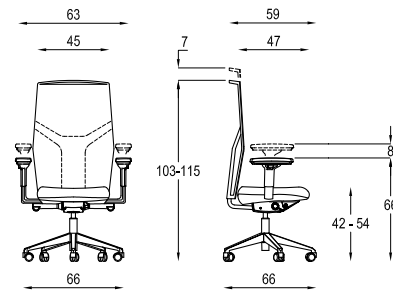

Siege operatif, dossier en polypro ou resille blanc ou noir, ou rembourré réglable en hauteur. Assise en polyurethane et revetu. Synchron. Pietment 5 rayons en nylon blanc ou noir ou en aluminium sur roulettes engomé. Accoudoirs réglable ou fixes. Optional: tetiere.

Siege operatif, dossier en polypro ou resille blanc ou noir, ou rembourré réglable en hauteur. Assise en polyurethane et revetu. Synchron. Pietment 5 rayons en nylon blanc ou noir ou en aluminium sur roulettes engomé. Accoudoirs réglable ou fixes. Optional: tetiere.

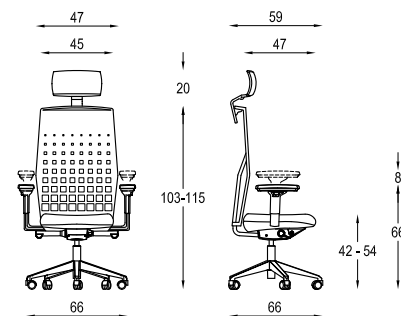
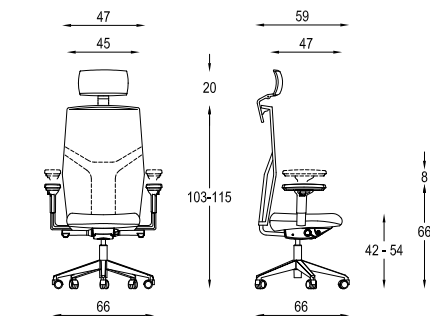
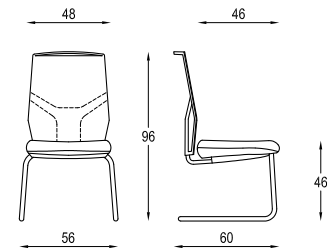

## Five

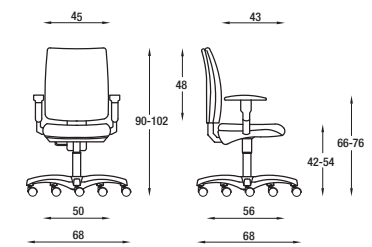

Sedia operativa, base nylon nera di serie, con braccioli fissi o regolabili. Disponibile in versione a gas contatto permanente, synchron o come visitatore su telaio slitta. La serie comprende anche lo sgabello.

Task chair, with standard black nylon base. With fixed or adjustable arms; with permanent contact gas-lift, or synchron mechanism or as visitor chair with cantilever frame. Even the stool is included in this collection.

Série de séances dactyle. La base est en nylon noir, avec accoudoirs fixes ou réglables. Disponible en version à gaz ou synchron.

Serie de sillas dactilo. Base nylon negra. Con brazos fijos o ajustables. Disponible en versión gas o synchron, y confidante con patin o taburete operativo.

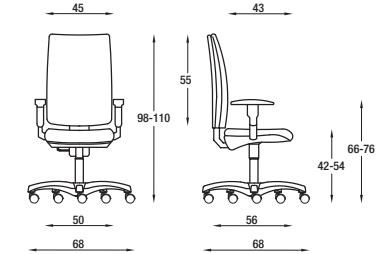
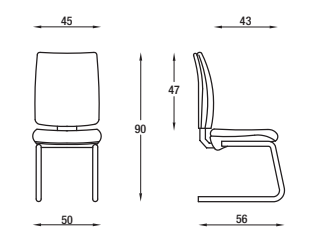
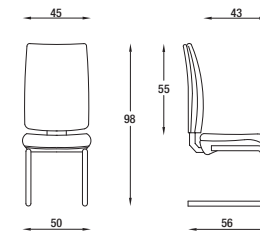

## Flash

Sedia operativa, schienale alto in rete ergonomica con supporto lombare regolabile in altezza. Seduta imbottita in poliuretano e rivestita. Meccanismo synchron. Base a 5 razze in nylon nera di serie e optional in alluminio pressofuso lucido, su ruote gommata e autotrenanti. 3 tipi di braccioli: fissi in polipropilene, o in poliuretano morbido ovali oppure regolabili in altezza. Personalizzabile con 8 colori di rete.

Task chair, high backrest with ergonomic mesh-net and lumbar support, adjustable in height. Seat padded in polyurethane foam and upholstered. Synchronized mechanism. 5-star black nylon base and optional in polished aluminium, on rubber and self-braking castors. 3 kind of armrests: fixed in polypropylene or in soft black polyurethane oval shaped, or adjustable in height. Available in 8 colors of mesh.

Fauteteuil operative. Elle offre le maximum du confort et elle se distingue pour sa versatilité. A vec le dossier en filet, disponible en 8 couleurs, et le support lombaire réglable en hauteur. Synchron mécanisme. La base est en nylon noir ou en aluminium. 3 types d'accoudoirs: polypropylène fixe, polyuréthane ou ovale doux ou réglable en hauteur.

Silla caracterizada por un respaldo de estructura metálica y polipropilene, tapizado con una malla ergonómica e indeformable, en 8 diferentes colores, lleva soporte lumbar ajustable en altitud. El asiento está acolchado y tapizado. Mecanismo de gas con movimiento sincronizado. Base a 5 radios de nylon negro o de aluminio, con ruedas engomadas. 3 tipologías de brazos: fijos at de polipropileno negro, fijos ovales de poliuretano negro, ajustables con partes de metal y apoyabrazos de poliuretano blando.

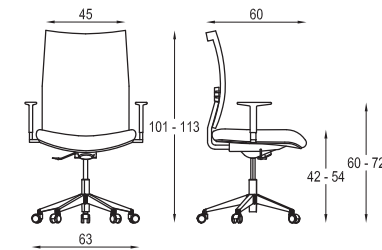
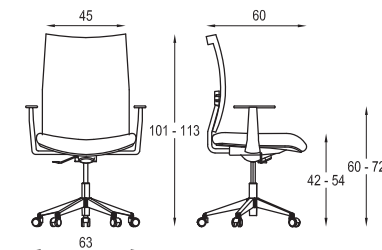

## Frame

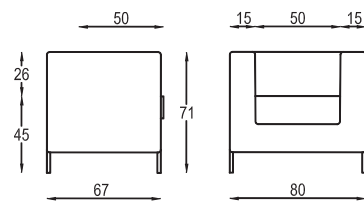

Poltrona, divano 2 e 3 posti, con struttura in multistrato di faggio, imbottitura in poliuretano espanso ad alta densità. Piedini in alluminio.

Armchair, 2 and 3seater sofa with structure in multilayer beech wood, and polyurethane padding. Aluminium feet.

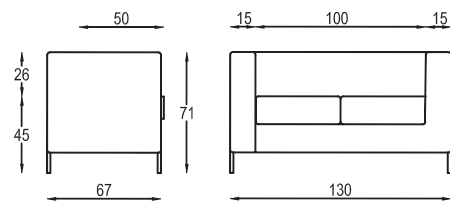

Fauteuil, canapé 2 places ou 3 places. Structure en hêtre et rembourré en polyuréthane. Pies de aluminium.

Sillón para la sala de espera, sofá de 2 o 3 asientos con estructura en multistrato de haya, acolchado de poliuretano esponjoso. Pies de aluminio.

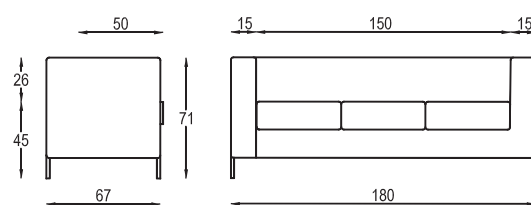

## Free

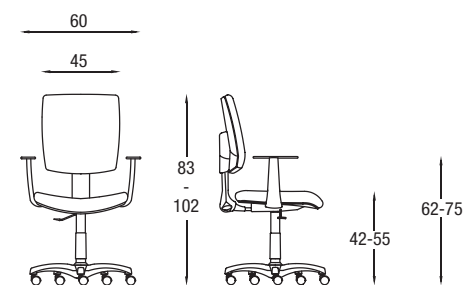

Serie di sedute dattilo con plastiche grigie, senza cuciture. Base nylon grigia di serie, con braccioli fissi grigi o regolabili. Disponibile in versione a gas o sincron.

Range of operator chairs in grey plastic, and seamless. Grey nylon base is standard, but aluminium base is also available; with fixed or adjustable arms; with gas-lift or synchron mechanism.

Série de séances dactyle avec plastiques grises, sans coutures. La base est en nylon gris, avec accoudoirs fixes gris ou réglables. Disponible en version à gaz ou synchron.

Serie de sillas dactilo con plásticos grigie, respaldo alto con costuras. Base nylon gris de serie, y con base de aluminio disponible. Con brazos fijos grises o regulables. Disponible en versión a gas o a sincron

## Free mesh

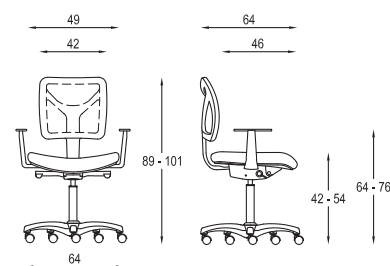

Poltrona operativa, schienale in rete, con supporto lombare regolabile in altezza. Sedile in poliuretano espanso ad alta densità, rivestito. Meccanismo minisincron. Base a 5 razze di nylon nero con ruote gommata e autofrenanti.

Optional: base alluminio; braccioli fissi o regolabili 3d (altezza, profondità e orientabili).

Siège opératif, avec dossier tapissé avec resille ou tissu, support réglable en hauteur. Mécanisme synchron. Piétement 5 rayons en nylon noir avec roulettes engoméé.

Optional: piétement en aluminium; accoudoirs fixes ou réglables 3d.

Task chair, mesh back, with lumbar support adjustable in height. Seat padded in high density polyurethane foam and upholstered. Mini synchron mechanism. 5-star black nylon base on rubber and self-braking castors.

Optional: aluminium base; fixed or 3d adjustable arms.

Silla operativa, con soporte lumbar ajustable en altura. Asiento acolchado de poliuretano expandido y tapizado. Mecanismo minisincron. Base 5 radios de nylon negro con ruedas engomadas.

Accesorios: base de aluminio; brazos fijos o ajustables 3d.

Seduta operativa con schienale alto, struttura in polipropilene nera. Schienale in rete, disponibile in 8 colori, o imbottito e rivestito, con supporto lombare regolabile, sedile imbottito in poliuretano espanso. Meccanismo sincron o traslatore. Braccioli fissi in polipropilene neri, o regolabili. Base a 5 razze in nylon nero o in alluminio pressofuso lucido, su ruote gommata e autofrenanti. Optional: appoggiatesta.

Siège de travail avec un design innovant. Elle offre le maximum du confort et elle se distingue pour sa versatilité. Avec le dossier en resille, disponible en 8 couleurs ou rembourré et le support lombaire réglable en hauteur, assise rembourrée. Mécanisme synchron, disponible avec réglage du profondeur. Base en nylon noir ou en aluminium, sur roulettes. Accessoires: appuie-tête, accoudoirs réglables.

Task chair, high backrest, structure in black polypropylene. Backrest in mesh-net available in 8 colors, or padded and upholstered, with adjustable lumbar support; seat padded and upholstered. Synchronized mechanism or with slidesystem. Fixed black polypropylene armrests or adjustable. 5-star black nylon base or in aluminum on rubber and self-braking castors. Optional: headrest.

Silla operativa, caracterizada por una linea ligera, estructura de polipropileno negro. Respaldo de rejilla, en 8 colores, o acolchado y tapizado, con soporte lumbar ajustable, y asiento acolchado. Base de nylon negro o en aluminio a 5 radios y con ruedas engomadas. Mecanismo sincronizado o con ajustador de profundidad. Brazos ajustables o fijos de polipropileno negro. Accesorio: apoyacabeza.

## Goal

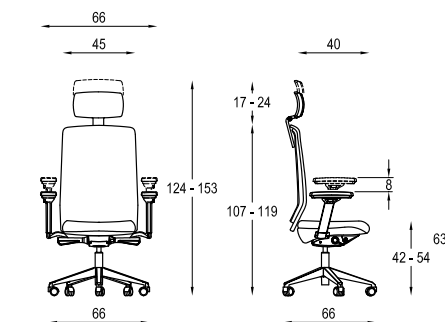
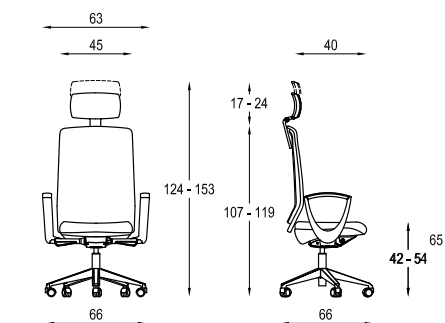
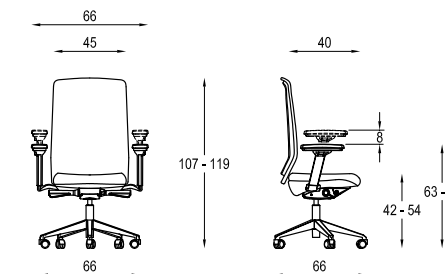
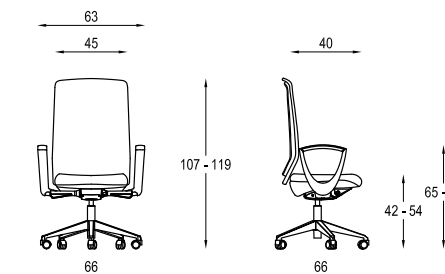

## Halfpipe

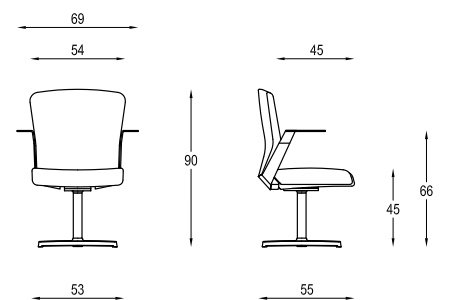
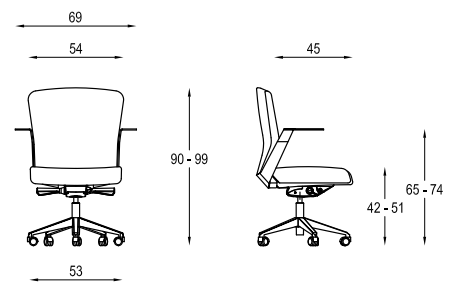
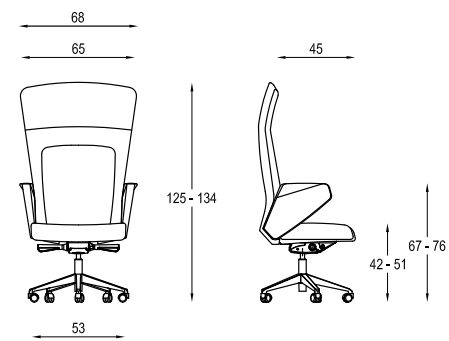
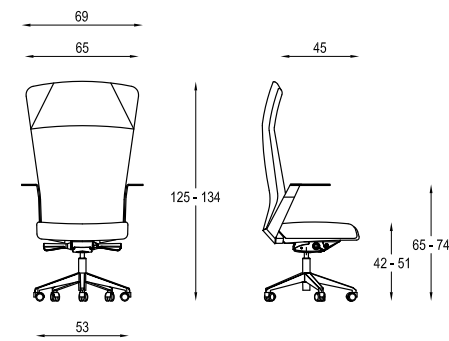

Linea di sedute dalle forme originali ed eleganti. La poltrona presidenziale è caratterizzata da uno schienale molto importante e dotata di un meccanismo sincronizzato auto pesante, che regola autonomamente l'intensità dell'oscillazione in funzione del peso corporeo dell'utilizzatore. La versione meeting e visitatore presenta uno schienale basso ed è disponibile su base a 5 razze in alluminio, oppure su telaio 4 lame con meccanismo di ritorno in posizione, ideale per le sale riunioni, o ancora su telaio slitta. Due varianti di bracciolo: totalmente imbottiti per una variante più classica o in alluminio lucidato.

Ligne de fauteuils aux formes élégantes. Le fauteuil «Président» a un dossier très haut, équipé d'un mécanisme de synchronisation qui règle automatiquement la force de l'oscillation en fonction du poids du corps de l'utilisateur. Versions réunion et visiteur avec un base en aluminium à 5 branches ou un piétement à 4 branches avec mécanisme à retour automatique ou sur piétement luge. Deux variantes d'accoudoirs sont proposées: une version entièrement rembourrée ou une version en aluminium poli.

An original and stylish seating range. The high-backed executive armchair features a striking back and a synchronized weight-based mechanism which automatically adjusts the intensity of tilt according to the user's bodyweight. The meeting and visitor version has a lower back and is available on a 5-spur aluminium base; or on a 4-blade base with swivel and ping-back mechanism, ideal for boardrooms; or on a sled base. Two types of armrest are possible: fully upholstered or in polished aluminium.

Linea de sillas elegantes y originales. La silla presidencial tiene un respaldo alto y un mecanismo de auto regulación de peso, o sea la intensidad de regulación del respaldo es automática según el peso del usuario. Hay la versión reunión y confidente con base 5 radios y ruedas o con 4 radios y mecanismo de retorno o con base trineo cromada. dos diferentes tipologías de brazos: acolchados o de aluminio.

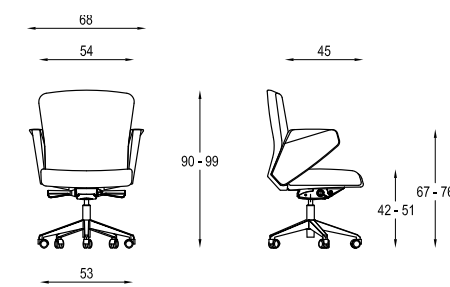
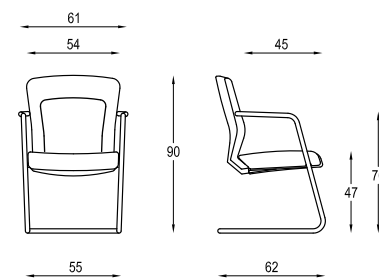
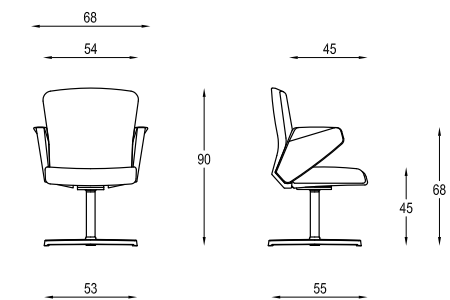

Poltrona, divano 2 e 3 posti, con struttura in multistrato di faggio, imbottitura in poliuretano espanso ad alta densità. Piedini in acciaio verniciati antracite.

Fauteuil, canapé 2 places ou 3 places. Structure en hêtre et rembourré en polyuréthane. Pies de acier vernizé gris.

Armchair, 2 and 3seater sofa with structure in multilayer beech wood, and polyurethane padding. Steel feet dark grey varnished.

Sillón para la sala de espera, sofá de 2 o 3 asientos con estructura en multistrato de haya, acolchado de poliuretano esponjoso. Pies de acero varnizado gris oscuro.

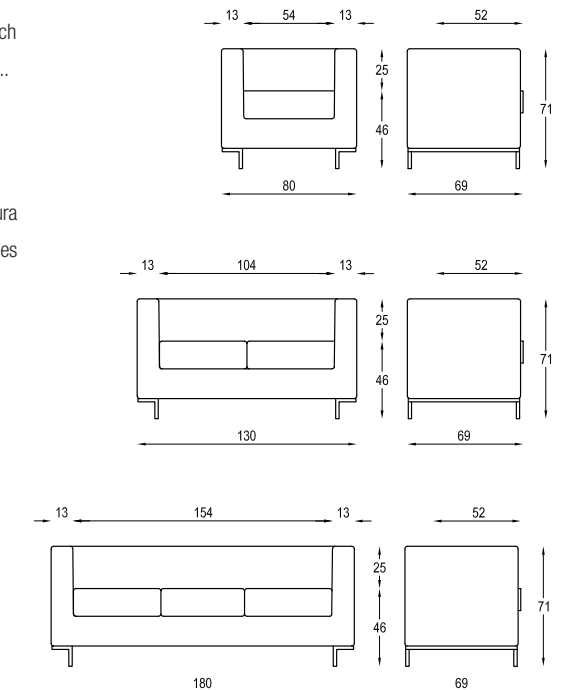
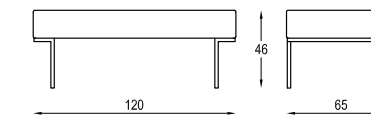

## Hall

## Ice

Seduta visitatore, in polipropilene colorato. Telaio 4 gambe cromato. Optional: sedile imbottito e rivestito, braccioli fissi e tavoletta scrittoio. Impilabile.

Chaise visiteur, en polypropylène. Structure en acier chromé, 4 pieds. Optional: seance rembourré en polyuréthane, accoudoirs et tablette écriteiro. Empilable.

Visitor chair, in polypropylene. 4 legs chromed frame. Optional: seat padded in polyurethane foam and upholstered, fixed arms, writing tablet. Stackable.

Silla confidente, respaldo en polipropileno negro o blanco, asiento acolchado en poliuretano. Estructura 4 patas cromadas. Accesorios: asiento acolchado y tapizado, brazos y mesa escritorio. Apilable.

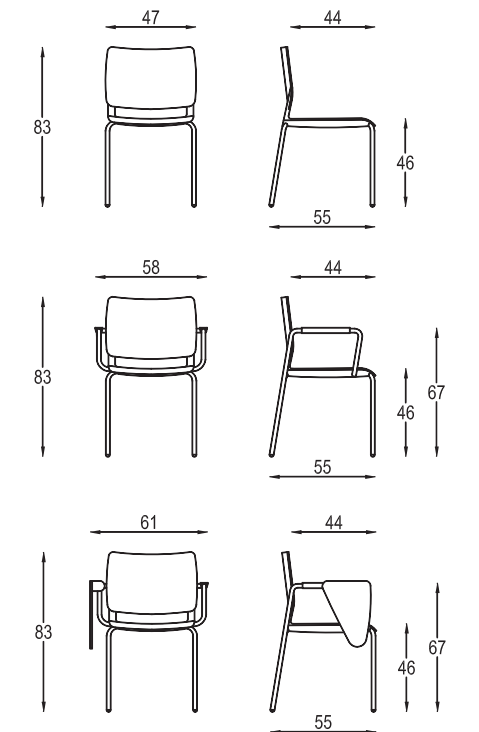

## Jazz

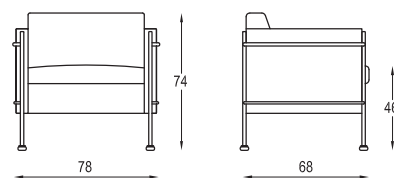

Poltrona 1 posto, divano 2 e 3 posti. Struttura in legno e acciaio cromato lucido, imbottitura in poliuretano espanso e piedini in acciaio cromato lucido.

Armchair, 2 and 3 seater sofa. Internal structure in wood and external structure in chromed polished steel. Padded in polyurethane foam and chromed steel feet.

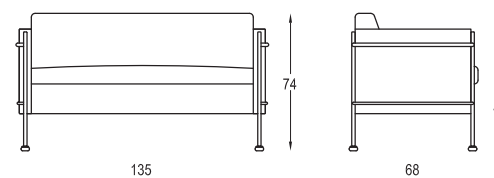

Fauteuil, canapé de 2 et 3 places. Coque de l'assise et du dossier en bois multiplis. Structure exterior en acier chromé poli. Rembourrage de polyuréthane, piétement en acier chromé poli.

Butaca, sofa de 2 plazas y de 3. Estructura interior de madera y exterior de acero cromado. Acolchado en poliuretano, con pies de acero cromado.

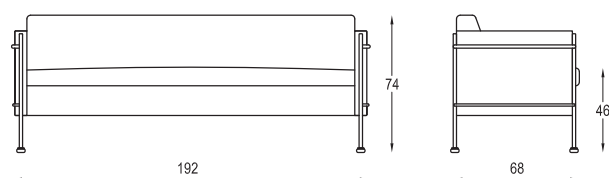

Poltrona visitatore, dal design minimal, confortevole e dalla spiccata versatilità, perfettamente idonea a più ambienti lavorativi. Caratterizzata dallo schienale in rete, disponibile in 8 colori diversi e seduta imbottita e rivestita. Base a 5 razze in nylon nero o in alluminio, con elevazione a gas, o con base fissa a slitta, cromata. Braccioli fissi in polipropilene bianchi o neri.

Visitor armchair, comfortable and versatile, perfectly suited to different working environment. Backrest in 8 colors of mesh, seat padded and upholstered. 5-star black nylon or aluminium base, or with cantilever chromed frame. Fixed black or white polypropylene armrests.

Fauteuil visiteur, dossier bas en resille, disponible en 8 couleurs, et seance rembourré en polyuréthane. Base en 5 rayons en nylon noir ou aluminium, ou sur patin chromé. Accoudoirs fixes en polypropylène noir ou blanc.

Silla de diseño elegante para, confortable y muy versátil, perfecta para diferentes entornos de trabajo. Caracterizado por un respaldo de malla disponible en 8 diferentes colores, y un asiento acolchado de poliuretano. Brazos fijos de polipropileno negro o blanco.

## Key

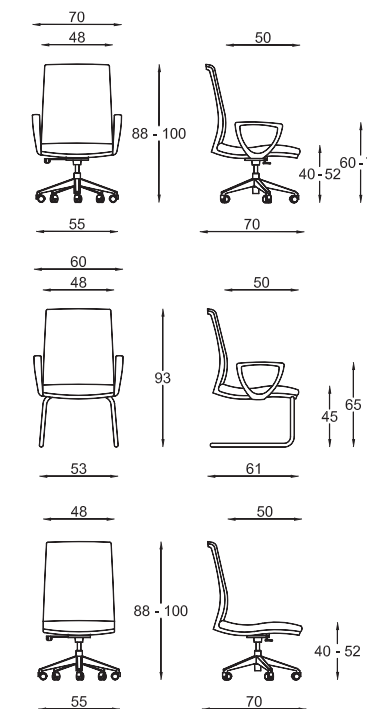

## Konté

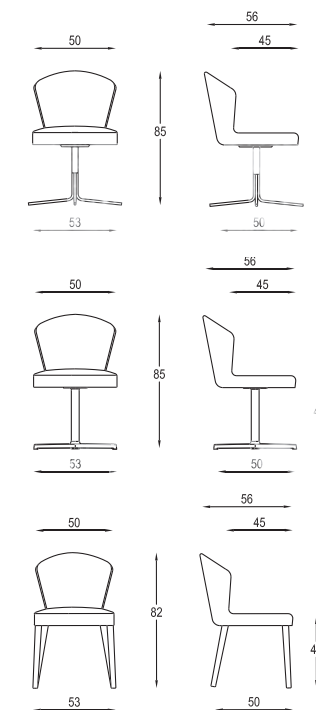

Poltroncina dalla linea elegante, struttura interna in acciaio e imbottita in poliuretano schiumato a freddo e completamente rivestita. Disponibile su vari basamenti: base girevole a 5 razze in alluminio con alzata gas su ruote gommate, base a 4 lame in alluminio con meccanismo di ritorno automatico, base girevole a 4 razze in tubolare di acciaio cromato, base piramidale di alluminio verniciata bianca o antracite o a 4 gambe in legno verniciato naturale o nero.

Elegant armchair with internal structure in steel, padded in cold-foamed polyurethane and completely upholstered. Available with different types of legs/bases: swivel base in chromed steel, 5-stars aluminium base on self-braking rubber castors with gaslift, 4-blades aluminium base with self-return mechanism, aluminium pyramidal base painted white or dark grey or 4 wood legs painted in natural shade or black.

Petit fauteuil élégant avec structure interne en acier, rembourré en mousse de polyuréthane à froid et complètement rembourré. Disponible avec différents piétements: 4 rayons tubulaires pivotante en acier chromé t, 5-rayons sur roulettes avec réglage hauteur gaz, 4-rayons en aluminium avec mécanisme de retour automatique, pyramidale en aluminium peint blanc ou gris foncé et 4 pieds en bois peint en teinte naturelle ou noirs.

Elegante butaca con estructura de acero acolchada de poliuretano espumado en frío. Disponibles con diferentes tipos de estructuras: giratoria de acero cromado, 5 radios de aluminio pulido con ruedas engomadas y elevador de gas, base de aluminio 4 radios con mecanismo de auto-retorno, piramidal giratoria de aluminio pintado blanco o antracita o 4 patas con acabado de madera barnizada en tono natural o negro.

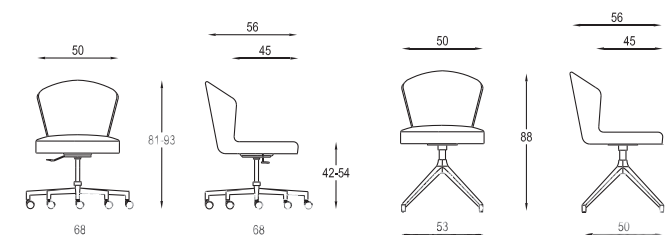

## Lead

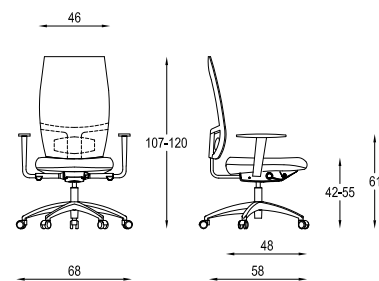

Poltrona operativa, caratterizzata dalla struttura in polipropilene antracite, schienale in rete oppure completamente rivestito, regolabile in altezza. Sedile in poliuretano espanso ad alta densità, rivestito. Meccanismo synchron. Base a 5 razze di nylon antracite con ruote gommata e autofrenanti.

Optional: supporto lombare regolabile in altezza e profondità; appoggiatesta in rete; base alluminio; braccioli fissi o regolabili; traslatore.

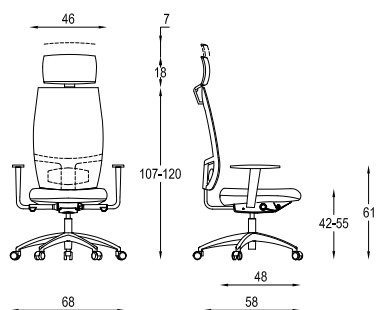

Siège opératif, avec la structure en gris foncé, dossier tapissé avec résille ou tissu, réglable en hauteur. Mécanisme synchron. Piètement 5 rayons en nylon gris foncé avec roulettes engoméé.

Optional: support lombaire réglable en hauteur et profondeur; piètement en aluminium; accoudoirs fixes ou réglables; têtière en résille; mécanisme de réglage de profondeur.

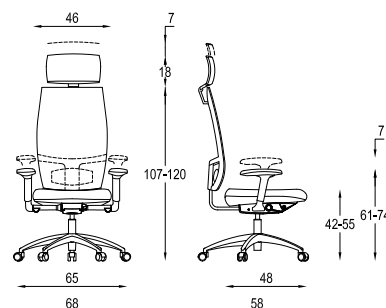
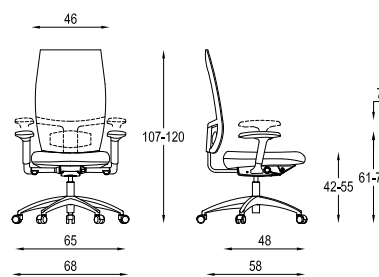

Task chair, characterized by dark grey colour structure, with mesh backrest or completely upholstered, adjustable in height. Seat padded in high density polyurethane foam and upholstered. Synchron mechanism. 5-star dark grey nylon base on rubber and self-braking castors.

Optional: lumbar support adjustable in height and depth; headrest in mesh; polished aluminium base; fixed or adjustable arms; slide system to adjust seat depth..

Silla operativa, caracterizada por la estructura de color gris antracita, con respaldo de rejilla o completamente tapizado, ajustable en altura. Asiento acolchado de poliuretano expandido y tapizado. Mecanismo sincronizado con base a 5 radios de nylon antracita y ruedas engomadas.

Accesorios: soporte lumbar ajustable en altura y profundidad, reposacabeza de rejilla; base de aluminio pulido; brazos fijos o ajustables; regulacion de profundidad del asiento.

## Liz

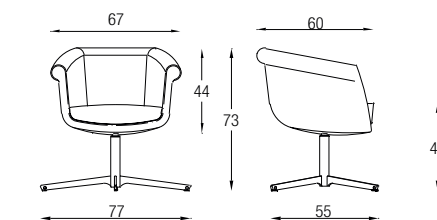

Armchair ideal for home and contract. Shell in steel and padded in injected foam on swivel 4 chromed blade frame, on 5 star aluminium base with castors, or on chromed round swivel base.

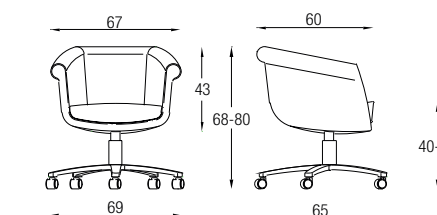

Sillón para la sala de espera y sala de reunión, en acero con acolchado de espumado a frío. Estructura de 4 radios en acero cromado, giratorio o con mecanismo a gas y base a 5 radios en aluminio con ruedas, o con base giratoria cromada.

Seduta ideale per il settore casa e contract, monoscocca in schiumato a freddo, disponibile su telaio a 4 razze cromato girevole, su base a 5 razze in alluminio pressofuso lucido con ruote o su base a campana, cromata.

Petit fauteuil pour salles d'attente et réunion avec mécanism à gaz ou 4 rais en acier chromé tournant ou avec piètement chromé tournant. La structure est en acier avec rembourrage écumé à froid.

## Liz

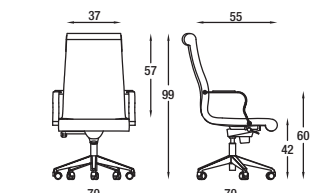

Executive armchair, extremely comfortable. Multilayer beech wood shell, padded in polyurethane foam. Knee-tilt mechanism on 5 star aluminium base on rubber castors. With fixed chromed armrests. Mid backrest is available even with 4 aluminium blades frame.

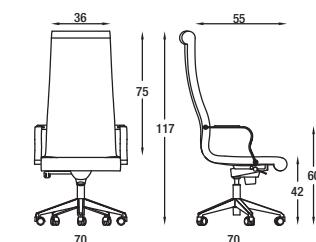

Sillón directivo, caracterizado por una linea elegante y ergonomica. Estructura de madera de haya y acolchada. Mecanismo knee-tilt con base de aluminio 5 radios y ruedas. Los brazos son fijos y cromados. La silla con respaldo medio puede tener la base de 4 radios en aluminio, giratoria.

Poltrona direzionale, con schienale alto o medio, caratterizzata dalle linee eleganti e dal massimo comfort. Scocca in multistrato di faggio, imbottita in poliuretano espanso. Meccanismo knee-tilt con base in alluminio 5 razze, su ruote autofrenanti e gommata. Con braccioli fissi cromati. La versione bassa è disponibile anche su telaio a 4 razze in alluminio.

Série de fauteuils de direction ou de présidence, caractérisés par une ligne classique et élégante qui offre un confort maximum. Knee-tilt mécanism sur base 5 rais en aluminium. Disponibles avec le base en aluminium; avec accoudoirs chromé. Le siège de direction peut avoir de base 4 rais en aluminium, pivotante.



## Liz

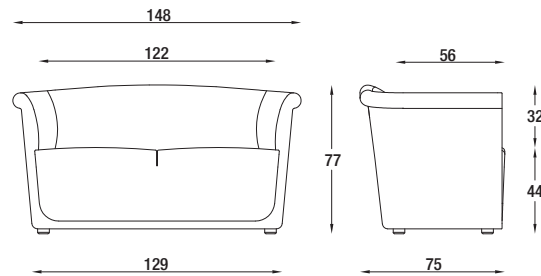

Poltrona 1 posto e divano 2 posti, dalle linee eleganti. Struttura interna in legno e imbottitura in poliuretano espanso. Piedini in polipropilene nero.

Armchair, and 2 seater sofa. Internal structure in wood, padded in polyurethane foam. Feet in black polypropylene.

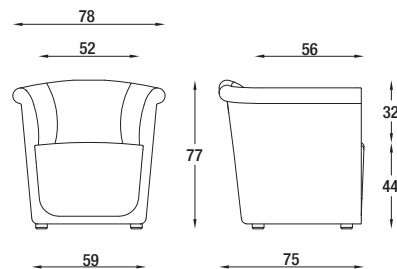

Fauteuil et canapé de 2 places. Coque de l'assise et du dossier en bois multiplis. Rembourrage de polyuréthane. Piètement en polypropylène noir.

Butaca y sofa de 2 plazas. Estructura interior de madera. Acolchado en poliuretano. Pies de polipropileno negro.

## Margarita

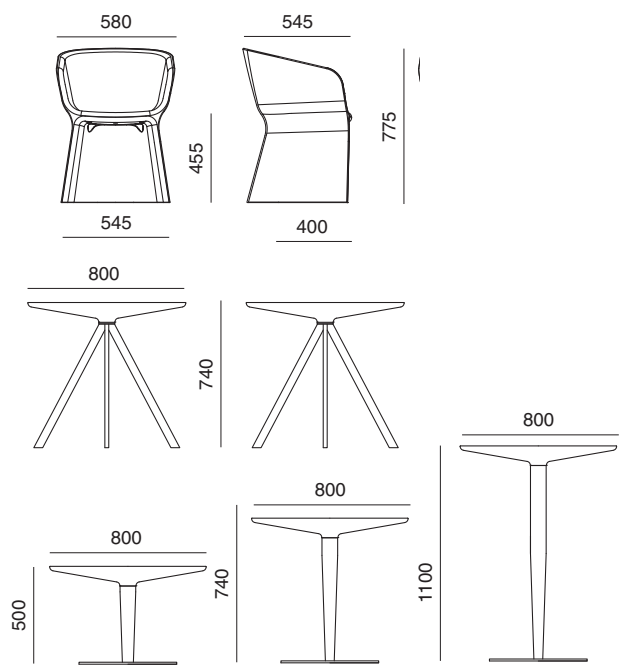

Poltroncina dalle linee moderne, ideale per sale d'attesa e riunione. Disponibile in polietilene colorato in diverse tonalità (bianco, tortora, antracite, rosso, verde e giallo) adatta ad un utilizzo anche outdoor, o con cuscinetto accessorio imbottito e rivestito, oppure ancora totalmente rivestita.

Armchair with modern lines, perfect for reception areas and meeting rooms. Available in colored polyethylene (white, dove, dark grey, red, green, yellow) which is suitable even for an outdoor environment, with a padded and upholstered cushion as optional, or it can be completely upholstered.

Fauteuil de style moderne, idéale pour les salles d'attente e de réunion. En polyéthylène, disponible en différentes couleurs (blanc, gris taupe, gris anthracite, rouge, vert et jaune) il peut être utilisé aussi à l'extérieur. Il peut avoir un coussin rembourré et tapissé ou même être complètement revêtu. Pieds réglables.

Butaca con líneas modernas, perfecta por salas de espera o reunión. Disponible en polietileno colorado (blanco, beige, antracita, rojo, amarillo, verde) para un utilizzo tambien exterior, con cojin asiento optional acolchado y tapizado, o puede ser completamente tapizada. Pies ajustables.

Tavoli, con top rotondo di diametro 80 cm in polietilene bianco o antracite, basamenti in metallo verniciato bianco o antracite a 4 gambe altezza 74 cm oppure centrale, in 3 diverse altezze: 50 cm, 74 cm e 110 cm.

Table with round top of 80 cm of diameter in polyethylene white or dark grey, frames in metal white or dark grey varnished, 4 legs 74 cm height, or central base in 3 different heights, 50 cm, 74 cm and 110 cm.

Table avec plan rond ø 80 en polyéthylène blanc ou gris anthracite, avec piétement en métal peinturé blanc ou gris anthracite à 4 pieds, hauteur 74 cm ou piétement central en 3 différents hauteur 50,74 et 110 cm.

Mesa con tope redondo de ø 80 cm, de polietileno colorado blanco o gris antracita, con estructura de metal varnizada blanca o antracita, 4 pies, altitud 74 cm, o estructura central, disponible en 3 diferentes alturas: 50 cm, 74 cm y 110 cm.

## Miss

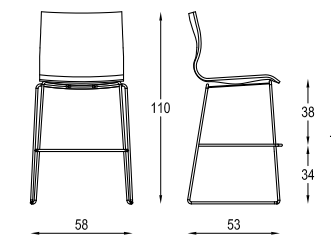

Range of compact armchairs characterised by a simple, curved design, highly versatile, ideal for the home or office. The shell is in multilayer beech wood, padded in polyurethane and upholstered. The base is available on 5 star base on castors with gaslift or knee-tilt mechanism, or on a swivel fixed height tubular or 4 blades frame with return mechanism, or on 4 legs chromed frame, or sled frame or on aluminium pyramidal base white or dark grey varnished. With or without chromed tubular armrests. Available even the fixed stool version.

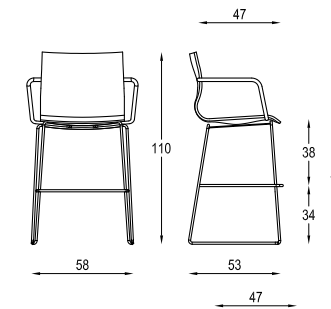

Série de petits fauteuils caractérisés par une ligne sinueuse et essentielle, d'un éclectisme marqué, idéale pour la maison, le contract et le bureau. La monocoque est en hêtre multicouche, rembourré et revêtu. La base peut être tournante sur roues avec élévation à gaz ou mécanisme kneetilt sur structure tournant, avec hauteur fixe en acier tubulaire ou 4 rayons en aluminium et retour automatique, ou sur 4 pieds fixes, ou sur patin ou sur 4 pieds aluminium verni blanc ou gris foncé. Avec ou sans accoudoirs en acier tubulaire chromé. Disponible en version tabouret fixe cjhromé.

Serie de sillas caracterizada por una línea sinuosa y esencial, de sobresaliente versatilidad, ideal por la casa, el contract y el despacho. La carcasa es de madera de hay, acolchada y tapizada. La basa puede ser de 5 radios con ruedas y elevacion a gas o mecanismo knee-tilt, o con estructura giratoria y altitud fija en tubular de acero o 4 radios de aluminio con retorno automatico en posicion, o de 4 pies fijos o patin cromado o base piramidal de aluminio barnizada blanca o antracita. Con o sin brazos de acero cromados. Disponible en version taburete fijo.

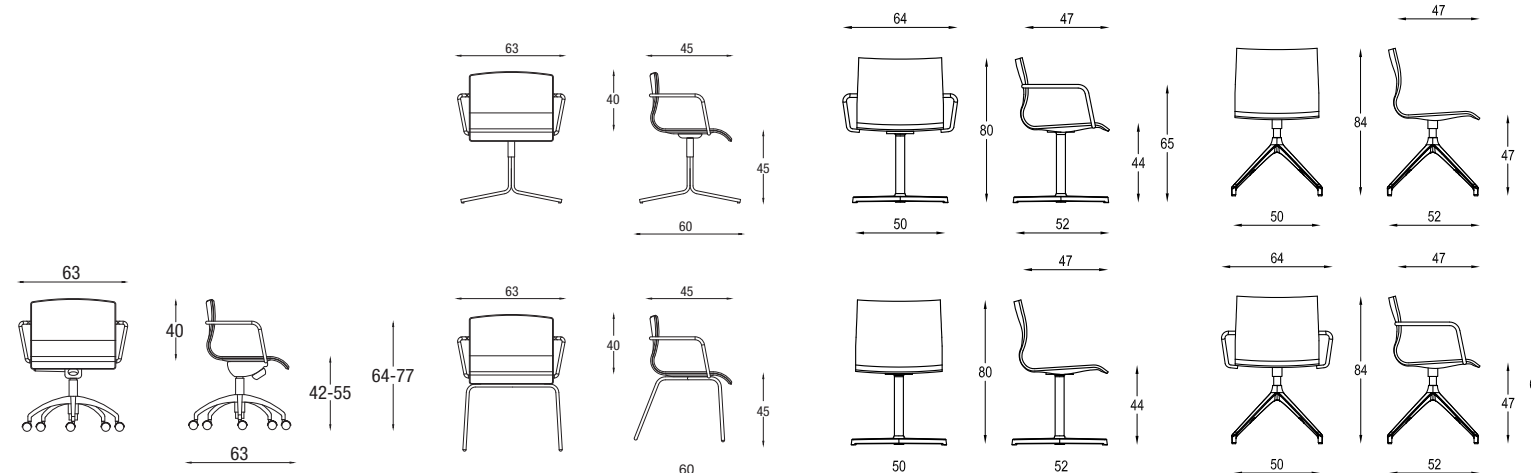
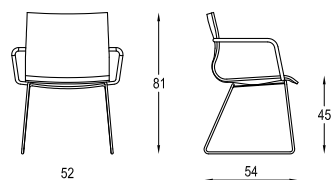
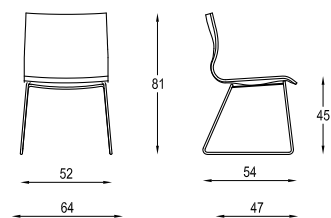

## Miss Lounge

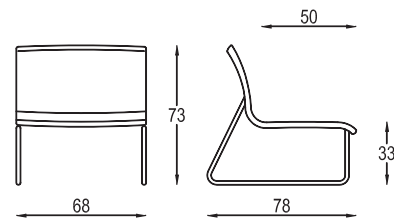

Poltrona lounge, struttura interna in multistrato di faggio, imbottitura in poliuretano espanso. Telaio slitta cromato.

Lounge chair, inner structure in multilayer beech wood, padded in polyurethane foam. Chromed sled frame.

Fauteuil lounge, coque en hêtre, rembourée en polyuréthane. Structure chromé, sur patin.

Sillon lounge, carcasa de madera de haya y acolchado de poliuretano. Estructura de acero cromado.

## Miss Panca

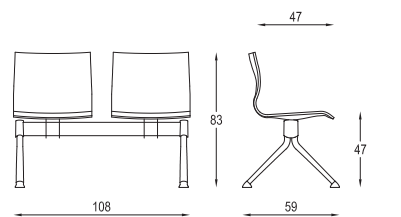

Seduta in multistrato di faggio, rivestita in tessuto o pelle con o senza cuciture trasversali, montata su barra nera con gambe in acciaio cromata da 2 a 5 posti.

Shell in multilayer beech wood, padded and upholstered. Chromed legs, beam available from 2 to 5-seater unit.

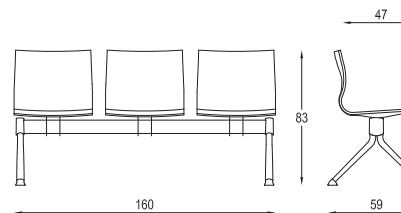

Séance en hêtre multi-couche et revêtue, avec pies en acier chromé. Disponible de 2 a 5 places.

Carcasa en multistrato de haya, acolchada y tapizada. Pies cromados. Bancada de 2 a 5 asientos.

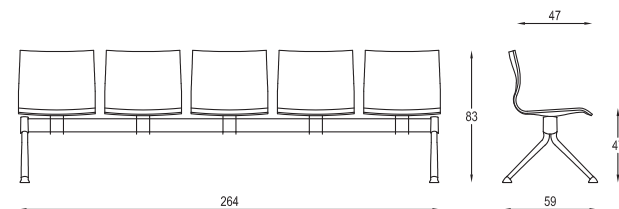
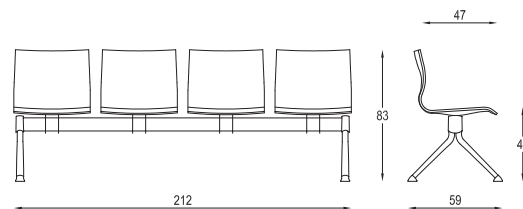

## Mister

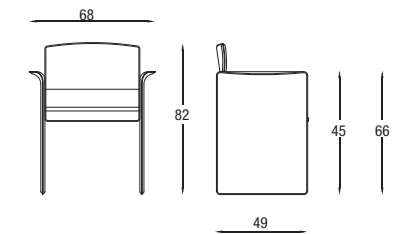

Poltroncina dalla forma elegante ed essenziale giusta alternativa alla tradizionale poltrona per visitatore. Con struttura in multistrato di faggio e barre in acciaio indeformabile. Può essere completamente rivestita con tessuto o pelle.

Compact elegant yet simple armchair, a perfect alternative to the traditional visitors' armchair. With a multilayered beech and non-deformable steel bar construction. It can be completely covered in fabric or leather.

Petit fauteuil à la forme élégante et essentielle, alternative au fauteuil traditionnel pour visiteur. Avec structure en hêtre multi-couche et barres en acier indéformable. Il peut être complètement revêtu en tissu ou en cuir.

Sillón de la forma elegante y esencial justa alternativa al tradicional sillón para visitador. Con estructura en multistrato de haya y barras de acero indeformable. Puede ser completamente revestida con tejido o piel.

## Miss Panca

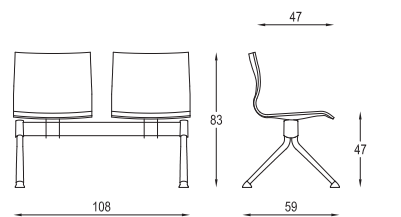

Seduta in multistrato di faggio, rivestita in tessuto o pelle con o senza cuciture trasversali, montata su barra nera con gambe in acciaio cromata da 2 a 5 posti.

Shell in multilayer beech wood, padded and upholstered. Chromed legs, beam available from 2 to 5-seater unit.

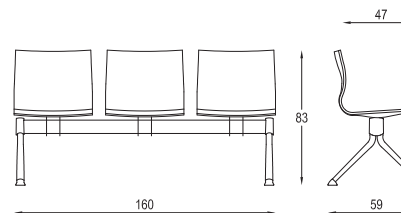

Séance en hêtre multi-couche et revêtue, avec pies en acier chromé. Disponible de 2 a 5 places.

Carcasa en multistrato de haya, acolchada y tapizada. Pies cromados. Bancada de 2 a 5 asientos.

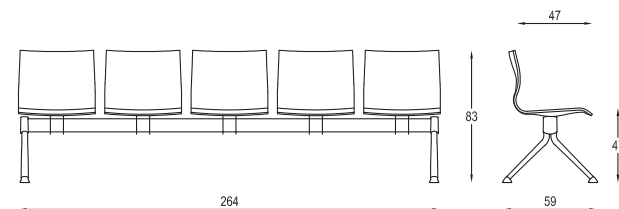
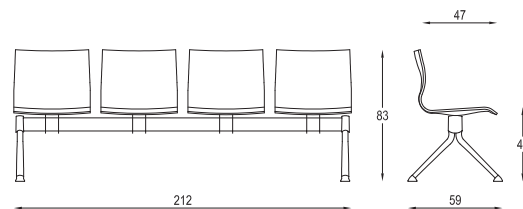

## Moon

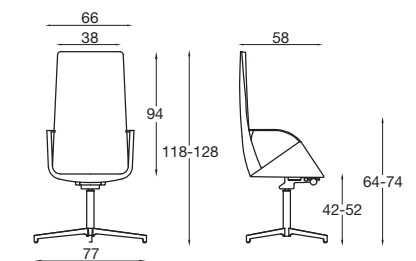

Poltrona direzionale, caratterizzata dalle linee eleganti e dal massimo comfort. Telaio cromato a 4 razze, seduta girevole. Disponibile con base girevole in alluminio 5 razze, su ruote autofrenanti e gommate con meccanismo sincron. I braccioli sono in alluminio.

Executive armchair, extremely comfortable, on 4 chromed, swivel blade structure. Available on 5 star aluminium base on castors and synchronized mechanism, with aluminium armrests.

Série de fauteuils de direction ou de présidence, caractérisés par une ligne classique et élégante qui offre un confort maximum. Disponibles avec le base en aluminium; avec accoudoirs en aluminium.

Sillones directivos, caracterizados por una linea elegante. Con base de acero a 4 radios. Disponible con base de aluminio 5 radios y mecanismo sincronizado. Los brazos son en aluminio.

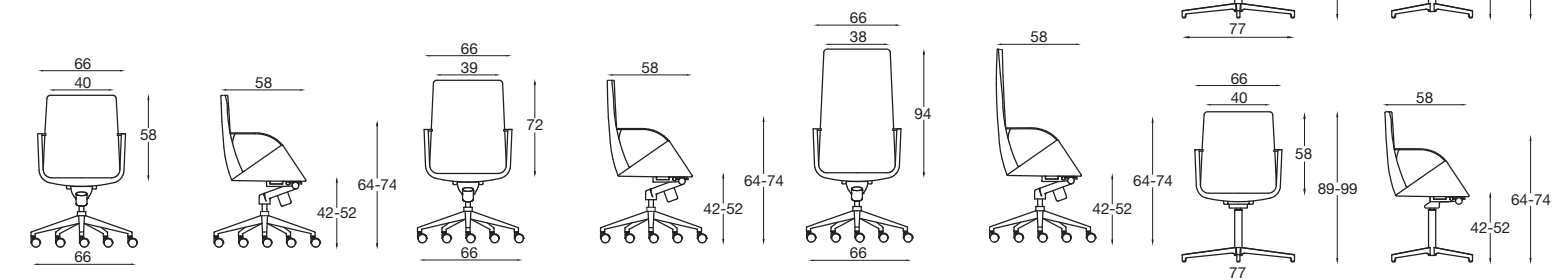

## Nest

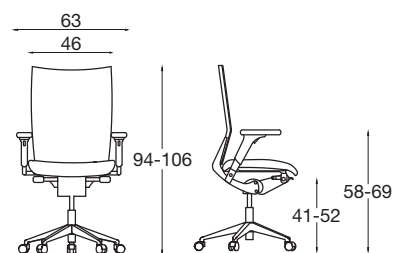

Poltrona direzionale con schienale con struttura in alluminio presso fuso lucido in rete o in tessuto, supporto lombare regolabile, base in alluminio pressofuso lucido, meccanismo sincron, braccioli regolabili in altezza con supporto in alluminio presso fuso lucidato.

Executive chair, high backrest with polish aluminium with mesh net or fabric, seat in polyurethane padding, lumbar support adjustable in height. Aluminium 5 star base on castors, synchron mechanism, adjustable arms.

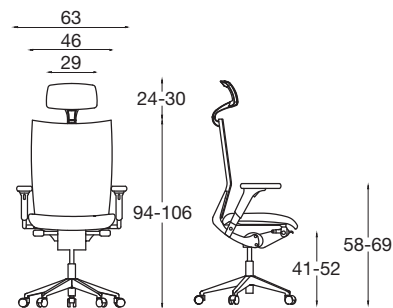

Fauteuil directionnel. Elle offre le maximum du confort. Le dossier avec structure en aluminium, le support lombaire réglable en hauteur. Base en aluminium, avec accouvoirs.

Silla de directivos, respaldo alto con estructura de aluminio y red o tejido, asiento acolchado en poliuretano y soporte lumbar ajustable en altitud. La base es en aluminio a 5 radios y con ruedas, mecanismo sincron, brazos ajustables.

## Oblò

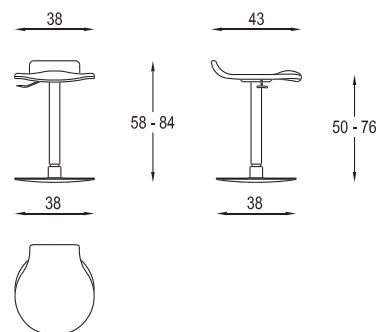

Sgabello innovativo multiuso, ideale per la seduta attiva e a breve termine grazie alla base oscillante. Base rotonda con colonna centrale in metallo verniciato nero a polveri epossidiche con alzata gas, trattamento anti-scivolamento del basamento oscillante; seduta sagomata con struttura in legno multistrato imbottita in schiuma di poliuretano e rivestita.

Multipurpose innovative stool, ideal for active and short-term sitting thanks to the swinging base. Round metal base painted in black epoxy powdercoated with gaslift, anti-slip treatment of the oscillating base; Shaped wooden seat, padded in polyurethane foam and upholstered.

Tabouret innovant polyvalent, idéal pour les sessions actives et de courtedurée grâce à sabase oscillante. Piètement en métal rond peint en poudre époxy noire avec élévation gaz, traitement antiglissement de la base oscillante; assise en bois multicouche moulée, rembourré en mousse de polyuréthane et revêtue.

Taburete innovador multiusos, ideal para asiento activo y de corto plazo gracias a la base oscilante. Estructura redonda de metal barnizado con pintura epoxi, elevador de gas y base oscilante con tratamiento anti-deslizante; asiento moldeado realizado en madera, con acolchado de espuma de poliuretano y acabado tapizado.

## Origami

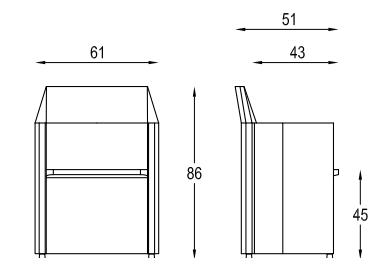

Pozzetto, ideale per sale conferenze, riunioni e d'aspetto. Inerno in acciaio e imbottitura in schiumato a freddo. Richiudibile e impilabile orizzontalmente. Su ruote o piedini. Optional: tavoletta scrittoio.

Tub chair, perfect for conference, meeting and waiting rooms. Inner structure in steel and padding in injected foam. Completely foldable and stackable in horizontal way. On feet or castors. Optional: writing tablet.

Petit fauteuil pour salles de conférence et réunion. Structure en acier moussé à froid, assise pliant et empilable horizontalement. Sur roulettes ou pieds. Disponible avec tablette écriteiro.

Butaca, perfecta por salas de conferencia, mesas de reunion y espera. Estructura de acero y acolchado de poliuretano iniectado. Pliable y apilable horizontalmente. Con ruedas o pies. Opcional: mesa escritorio.

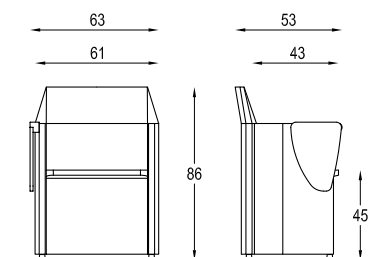

## Oxford

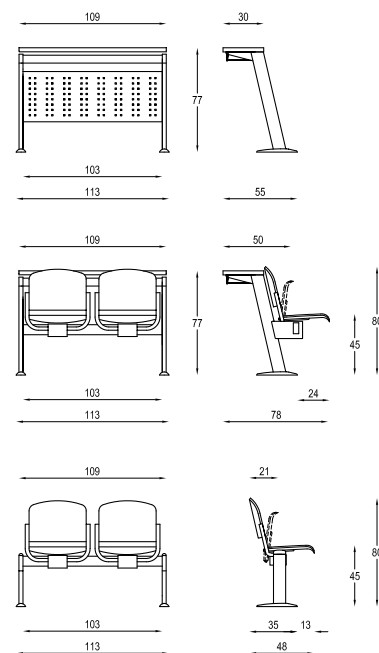

Sistema di sedute e piani a 2 e 3 posti, ideale per sale formazioni, auditorium e aule università, con sedile ribaltabile. Versione in legno verniciato naturale o imbottita e rivestita.

2 or 3-seater seating system with writing boards, perfect for training rooms, auditoriums or university spaces, with tip up seat. Available in multilayer beech wood, natural painted, or padded and upholstered version.

Système d'assises et bancs de 2 et 3 places, idéal pour les salles de formation, les auditoriums et les salles de classe des universités, avec assise pliant. Version en bois verni ou rembourrée et revetue.

Sistema de asientos de 2 o 3 plazas y mesas escritorios, perfecto para salas de fomacion o universidades, con asiento plegable. Hay la version de madera varnizada natural o la version acolchada y tapizada.

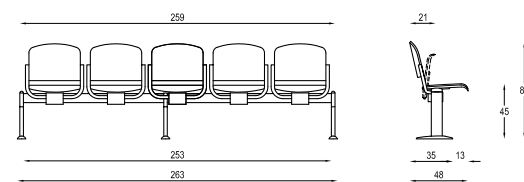
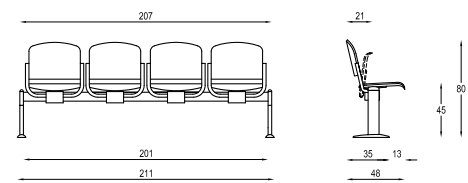
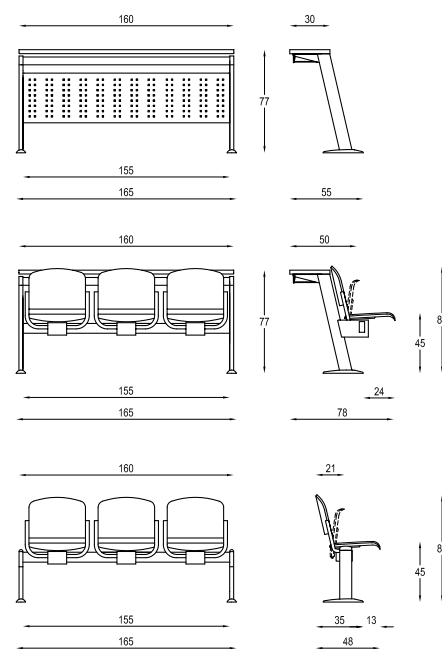

## Pass

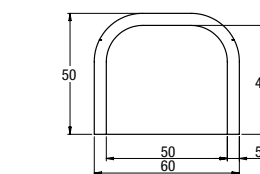
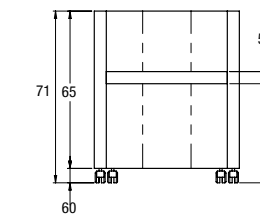

Pozzetto, ideale per sale riunioni e d'aspetto. Inerno in legno con imbottitura in poliuretano espanso, con braccioli. Su ruote o piedini.

Tub chair, perfect for meeting and waiting rooms. Inner structure in multilayer beech wood and padding in polyurethane foam, with armrests. On feet or castors.

Petit fauteuil à la forme linéaire pour salles d'attente et réunion. Structure en bois, rembourrée en mousse polyuréthane. Sur roulettes ou pieds.

Butaca, perfecta por mesas de reunion y espera. Estructura de madera y acolchado de poliuretano. Con brazos. En ruedas o pies.

## Prince

Sgabello dalla linea morbida e sinuosa, con monoscocca in multistrato di faggio con schienale alto o basso, rivestimento in pelle e tessuti. Disponibile nella versione con elevazione a gas e base tonda cromata o cromo/satinata, oppure su telaio in tubolare d'acciaio cromato a quattro razze. Su tutti viene montato un appoggiatesta in tubolare d'acciaio.

Stool with a soft, curved design, in one-piece of multilayered beech with a tall or low backrest, covered in leather or fabric. Available in gas height adjustment and with a round chromed (or chromed/satinated) base, or a tubular chromed steel frame with four blades. All equipped with footrests in tubular steel.

Tabouret à la ligne souple et sinueuse avec monocoque en multicouche de hêtre avec petit dossier haut ou bas, revêtement en cuir et en tissu. Disponible dans la version avec élévation à gaz et base ronde chromée ou sur structure en acier tubulaire chromé à quatre rayons. Un repose-pied en acier tubulaire chromé est monté sur tous les modèles.

Taburete de la línea blanda y sinuosa, con monocasco en multicouche de haya con respaldo alto o bajo, revestimiento en piel y tejidos. Disponible en la versión con elevación a gas y a base redonda cromada o cromo/satinada, o bien sobre telar en tubular de acero cromado a cuatro radios. Sobre todo es montado un apoyapies en tubular de acero.

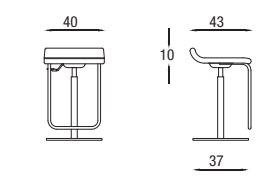
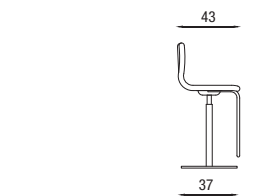

## Qubiq

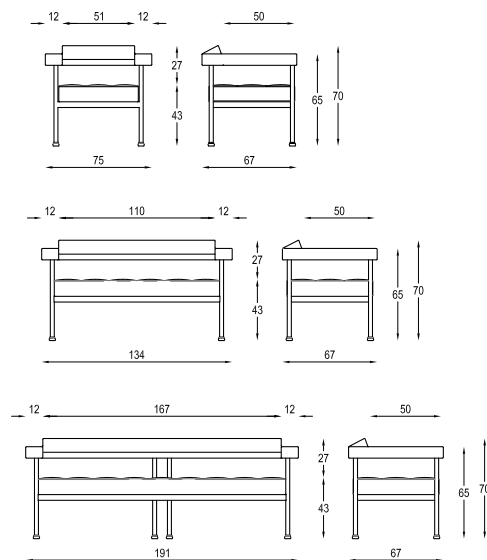

Poltrona, divano 2 e 3 posti, struttura in multistrato di faggio, imbottitura in poliuretano espanso ad alta densità. Struttura cromata.

Armchair, sofa 2-seater and 3-seater, structure in multilayer beech wood, and polyurethane padding. Chromed structure.

Fauteuil, canapé 2 et 3 places, Structure en hêtre et rembourré en polyuréthane. Pietment chromé.

Butaca, sofa 2 y 3 asientos, con estructura en multistrato de haya, acolchado de poliuretano esponjoso. Estructura cromada.

## Queen

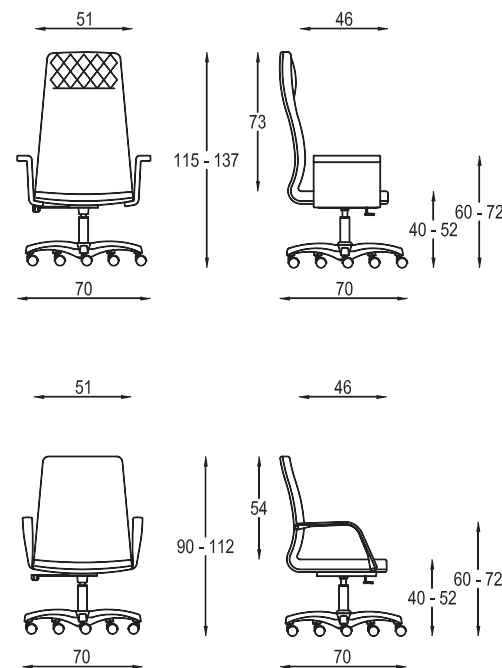

Sedia direzionale e presidenziale, con scocca in multistrato di faggio e imbottitura in poliuretano espanso, con extra imbottitura su seduta e poggiatesta in Memory Foam. Meccanismo alzata a gas o knee-tilt. Base a 5 razze in nylon nero o in alluminio su ruote gommate e autofrenanti. Braccioli fissi in nylon nero o imbottiti e rivestiti.

Executive and presidential office chair, shell in multilayer beech wood, padded in polyurethane foam and extra padding on seat and headrest in memory foam. Gaslift or knee-tilt mechanism. 5-star black nylon base or in aluminium on rubber and self-braking castors. Fixed armrests in black nylon or padded and upholstered.

Ligne de fauteuils de direction ou de présidence, caractérisés par une ligne classique et élégante. Coque en hêtre, rembourrée en polyuréthane et avec un extra rembourrage sur seance et sur appui-tête en Memory foam. Disponibles avec mécanisme à gaz ou synchron; option d'accoudoirs rembourrés ou fixes en nylon. Base à 5 rayons en nylon ou aluminium, sur roulettes.

Sillon de directivos, respaldo medio o alto, estructura de madera de haya, acolchado de poliuretano e memory foam en el asiento y en el reposacabeza. Mecanismo de gas o knee-tilt. Base a 5 radios de polipropileno negro o de aluminio con ruedas engomadas. Brazos fijos de nylon negro o acolchados y tapizados.

## Red Hot Sgabello

Sgabello a 4 gambe cromato o a basamento centrale con alzata gas. Scocca in polipropilene colorato: bianco, azzurro, giallo o antracite.

Stool on 4-chromed legs or with round chromed base with height adjustment. Shell in polypropylene available in different colors: white, sky blue, yellow or dark grey.

tabouret fixe chromé à 4 pieds ou avec pietément central avec élévation gaz. Coque en polypropylène disponible en 4 couleurs différentes: blanc, bleu clair, jaune ou gris foncé.

Taburete con base cromada fija a 4 patas o con subida a gas y base redonda. Carcasa de polipropileno disponible en diferentes colores: blanco, azul, amarillo o antracita.

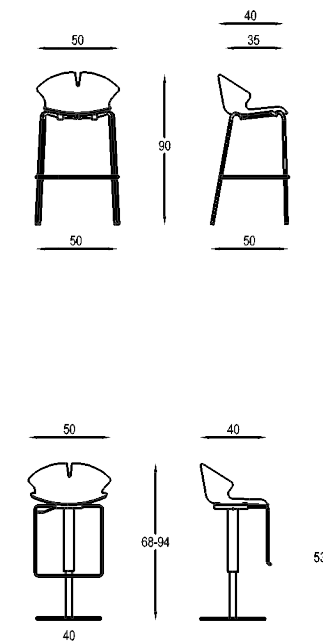

## Slim

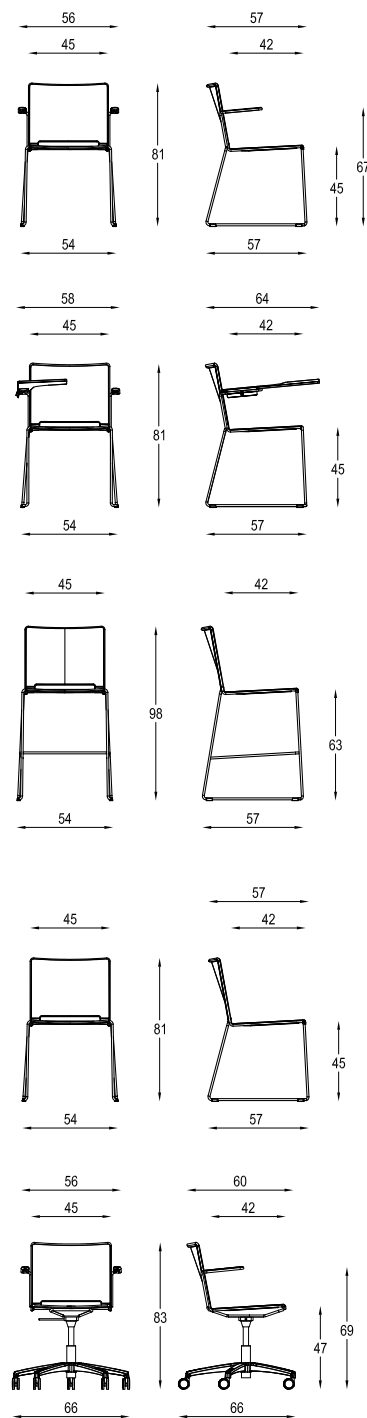

Sedia ideale per sale conferenze, come visitatore o attesa, ad alta impilabilità. Sedile e schienale in polipropilene colorato (bianco, nero, grigio e sabbia), su telaio slitta cromato o verniciato nero o bianco, con o senza braccioli. Optional: tavoletta nera in hpl, agganci per fissare la posizione in file, e carrello per portare le sedie, sedile imbottito e rivestito. Disponibile anche nella versione su gas, con base bianca, nera o in alluminio pressofuso lucido a 5 razze, su ruote gommata e auto frenanti. La versione panca a 2,3,4,5 posti è perfetta per sale attese e reception. È possibile avere anche lo sgabello, con telaio cromato.

Chaise pour salle de conference ou visiteur, empilable. Assise et dossier en polypropylène blanc, gris, noir ou beige, avec structure patin chromé ou verni blanc ou noir, avec ou sans accoudoirs. Optional: tablette ecriteiro en hpl noir, accroches, chariot et assise rembourré et revetu. Disponible aussi en version gaz sur base blanc, noir ou aluminium 5 rayons avec roulettes engomé. Version sur poutre 2/3/4/5 places pour salle de reception. La version taburet c'est avec le pietment fixe chromé.

Chair ideal for conference rooms and as visitor, stackable. Seat and back in colored polypropylene (white, black, grey and sand), on sled frame, chromed, white or black painted, with or without arms. Optional: black tablet in hpl, links to fix the chairs in rows, and trolley to carry the stacked chairs, and padded seat. Available even with gaslift and black, white or aluminium 5-star base on rubber and self-braking castors. Bench version for 2 / 3 / 4 / 5 – seater is perfect for halls and reception areas. It is available in the stool version, with chromed frame.

Silla ideal por salas de conferencia o como confidente. Asiento y respaldo de polipropileno colorado (negro, blanco, beige o gris) con estructura de patin cromada o barnizada blanca o negra, con o sin brazos. Apilable. Optional: pala de escritura de hpl negro, piezas de union, asiento acolchado y tapizado. Disponible también en version su gas y 5 radios con ruedas engomadas. Sistema de bancada a 2 / 3 / 4 / 5 asientos perfecto para salas de espera. La version taburete es disponible con base fija cromada.

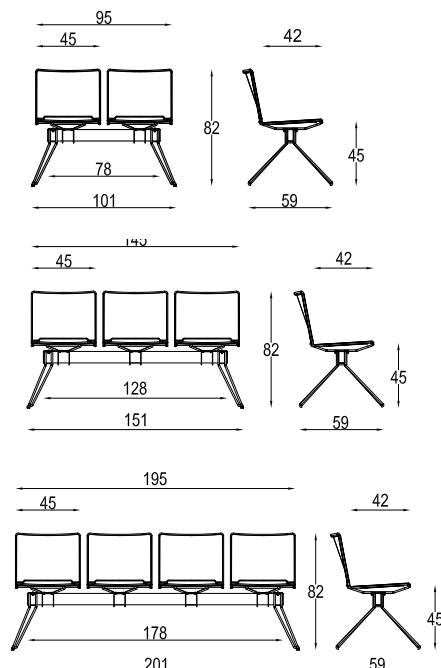

## Social

Seduta visitatore, schienale imbottito in poliuretano espanso o in rete, sedile imbottito e rivestito. Telaio slitta cromato o 4 gambe, con braccioli fissi e copribraccioli in polipropilene nero. Impilabile.

Siège visiteur, dossier haut rembourré en polyuréthane ou dossier bas en resille, assise en polyuréthane revetue. Structure patin chromé ou 4 pieds, avec accoudoirs fixes. Empilable.

Visitor chair, backrest padded in polyurethane foam and upholstered or in mesh net, seat padded and upholstered. Chromed cantilever frame or 4 legs, with fixed arms and cover arms in polypropylene. Stackable.

Silla confidente, respaldo acolchado y tapizado o de rejilla, asiento acolchado y tapizado. Estructura cromada trineo o 4 patas, brazos fijos. Apilable.

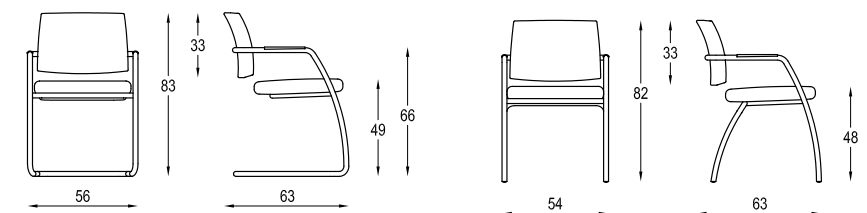

## Square

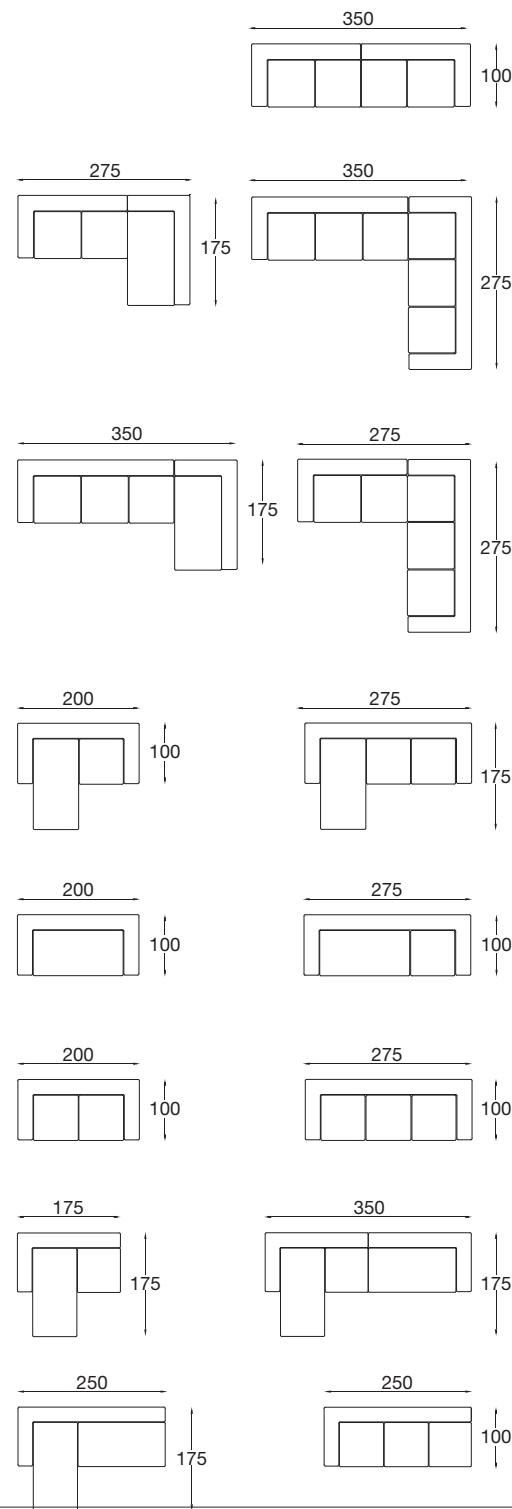

Divano composto da basi per singola o doppia seduta, versatile in quanto componibile e adattabile a qualsiasi tipo di spazio ed esigenze. Struttura portante in legno e pannelli in agglomerato di legno rivestito con poliuretano espanso indeformabile e tessuto protettivo accoppiato. Il meccanismo di molleggio della seduta è composto da cinghie elastiche. Il rivestimento del divano può essere in tessuto completamente sfoderabile o in pelle, non sfoderabile. I cuscini hanno un'imbottitura di gommapiuma e sono rivestiti in tela di cotone.

Canapé composé avec bases pour individuelle ou séance, éclectique puisque encastrable et adaptable à n'importe quel type d'espace et exigence. Structure en multiplis et bois aggloméré recouvert d'une mousse indéformable de polyuréthane et doublée de fibres de polyester. Le mécanisme est composé de sangles élastiques qui permettent un meilleur confort. Le revêtement peut être en tissu, complètement amovible ou en peau fixée. Les coussins décoratifs sont en "multifill" et recouverts d'une doublure protectrice en coton.

Sofa composed of bases for single or double seater, adaptable to any type of space and requirements. Wooden frame with beech multiply panels upholstered in non-deformable polyurethane foam and lined in protective polyester. The mechanism is made up of elastic belts to enhance comfort. Can be upholstered either with removable fabric covers or non-removable leather. The cushions are made of multifill and covered in a protective cotton lining.

Sofá compuesto por bases de uno o dos asientos, versátil en cuanto componible y adaptable a cualquier tipo de espacio y exigencias. Estructura portante de madera y paneles en multistrato revestido con poliuretano esponjoso indeformable y tejido protectorio junto. El mecanismo de muellaje del asiento está compuesto por correas elásticas. La tapicería del sofá puede ser en tejido completamente desenfundable o en piel, no desenfundable. Los cojines tienen un acolchado a caucho esponjoso y el tejido ed de algodón.

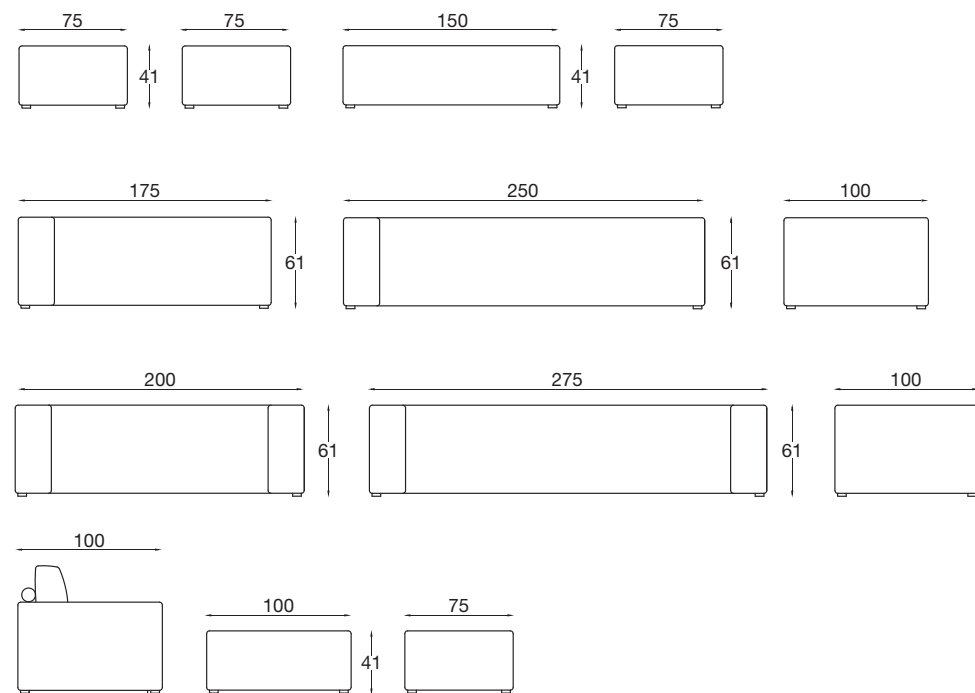

## Style

Seduta direzionale, con schienale ergonomico, dotato di supporto lombare regolabile in altezza, imbottita in schiumato a freddo, meccanismo sincron con traslatore, braccioli regolabili in altezza e orientabili in poliuretano morbido, e base a 5 razze in alluminio pressofuso lucido, su ruote. Disponibile la versione con appoggiatesta.

Fauteteuil directionnel, avec structure indéformable en moussé à froid, le support lombaire réglable en hauteur. Base en aluminium, avec accoudoirs réglables. Disponible avec repose-tête.

Executive chair, high backrest with lumbar support adjustable in height, injected foam padding, synchronized mechanism and slidesystem, adjustable armrests and 5 star polish aluminium base on castors. Available with headrest.

Silla de directivos, caracterizada por una linea ligera. Acolchada en espumado frio, la base es en aluminio a 5 radios y con ruedas, mecanismo sincronizado y adelantamiento del asiento, brazos ajustables en acero y poliuretano. Disponible con reposacabeza.

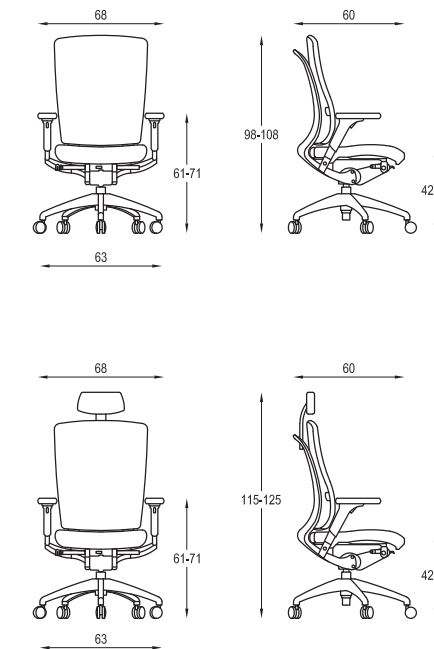

Seduta per la collettività, telaio 4 gambe verniciato nero o cromato, versione su gas e base a 5 razze con ruote, schienale in polipropilene bianco, imbottito e rivestito, la seduta è sempre imbottita e rivestita. I braccioli sono neri in poliuretano morbido, possibilità di tavoletta scrittoio e agganci fissi. Disponibile anche su panca.

Siège pour salle de conférence, châssis à 4 pieds chromé ou peint en noir, indéformable noir, ou en polypropylène blanc, ou revêtu et séance rembourrés. Disponible aussi avec accoudoirs noir, et tablette écriiroire.

Conference chair, black painted or chromed 4 legs frame, seat padded in polyurethane and upholstered, backrest in white polypropylene, or upholstered, with black soft polyurethane arms, writing desk and linking available. Version on gaslift and 5 star base on castors and on bench.

Silla para colectividad, con estructura 4 patas barnizada negra o cromada, asiento acolchado en poliuretano y tapizado, respaldo en polipropileno blanco o tapizado. Version con mecanismo de gas y base con ruedas, y en bancada.

## Sunny New

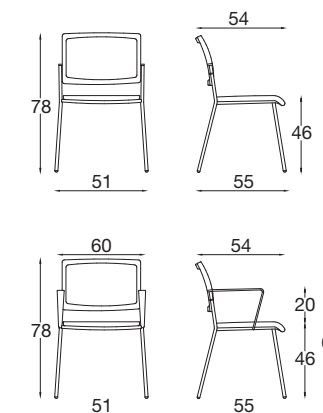

## Toffee

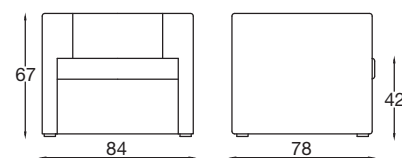

Poltrona d'attesa o divano 2 posti con struttura in multistrato di faggio, imbottitura in poliuretano espanso. Piedini in legno verniciato nero. Disponibile anche in versione 3 posti.

Single-seater waiting room armchair, two or three-seater sofa with structure in multilayer beech wood, padded in polyurethane. Veneered wood feet.

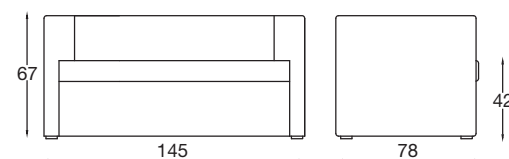

Fauteuil pour salle d'attente ou canapé à 2 places avec une structure en hêtre multi-couche, rembourrage en polyurethane expansé. Petits pieds en acier chromé. Aussi disponible en version à 3 places.

Sillón para la sala de espera o sofá de 2 asientos con estructura en multistrato de haya, acolchado en poliuretano esponjoso. Pies de madera pintado negro. Disponible también en versión de 3 asientos.

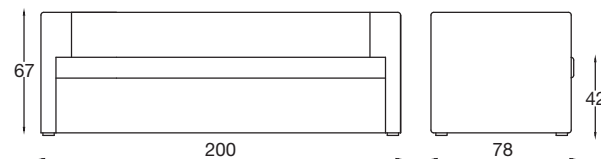

## Tronix

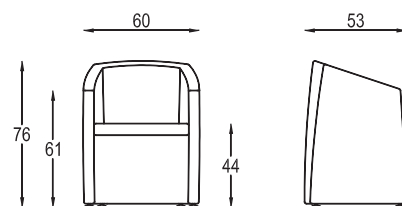

Pozzetto, dalla forma lineare ed elegante; ideale per qualsiasi ambiente: ufficio, sale riunioni, sale d'attesa ed alberghi. Con struttura indeformabile in acciaio schiumato a freddo, disponibile su ruote o piedini fissi. Optional: tavoletta con snodo antipanico.

Stylish tub armchair, perfect for any environment: offices, meeting rooms, waiting rooms and hotels. Structure in steel and padded in injected foam. Available on castors or with fixed feet. Optional writing tablet is available.

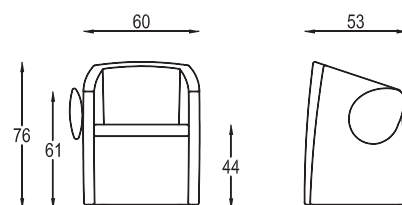

Fauteuil à la forme linéaire et élégante; idéale pour bureau, salles réunions, salles d'attente et hôtels. Avec structure indéformable en acier moussé à froid, disponible sur roues ou petits pieds fixes. Optional: tablette écriteoire.

Butaca linear y elegante; ideal para cualquier ambiente: oficinas, salas de reuniones, salas de espera y hoteles. Estructura de acero, acolchado de poliuretano espumado a frío, disponible con ruedas o pies fijos. Opcional: pala para escribir.

## Vanity

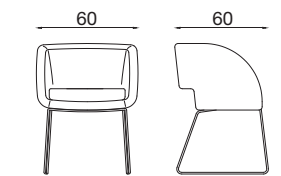

Waiting and meeting room chair, inner in steel and padding in injected foam. Available with gaslift mechanism, chromed sled or 4 legs frame, or 4 blades aluminium frame with return mechanism or with pyramidal base white or dark grey varnished.

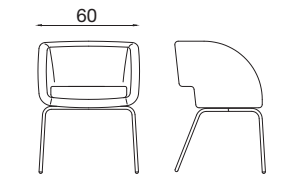

Petit fauteuil pour salles d'attente et réunion avec mécanisme à gaz ou sur châssis glisse et 4 jambes en acier tubulaire ou 4 rais en aluminium avec retour ou piétement pyramidal verni blanc ou gris foncé. La structure est en acier avec rembourrage écumé à froid.

Pequeño sillón para la sala de espera y sala de reunión con mecanismo a gas o estructura patin cromada, 4 pies en tubular de acero o telar giratorio con 4 radios en aluminio con retorno en posición. Carcasa de acero con acolchado de espumado a frío.

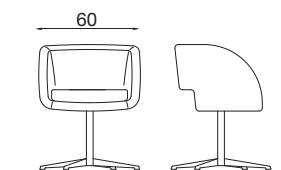
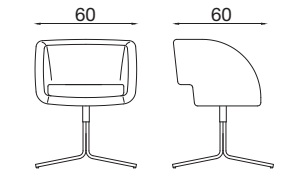
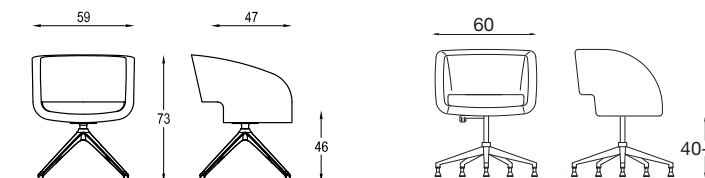

## Venus

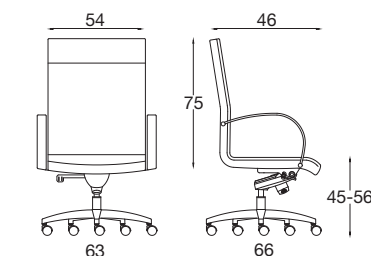

Range of armchairs for managers and top executives extremely comfortable, characterised by a classical design. 5 star aluminium base on castors and kneetilt mechanism, or visitor chair in cantilever chromed frame.

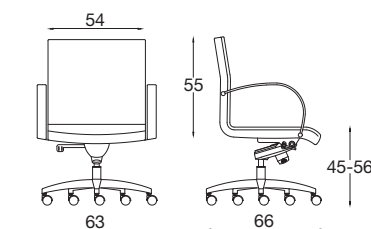

Série de fauteuils de direction ou de présidence, caractérisés par une ligne classique et élégante qui offre un confort maximum. Disponibles avec les rayons tournants ou avec base à coulisse en métal; il peuvent avoir l'accoudoir avec une partie rembourrée.

Sillones presidenciales y directivos, caracterizados por una línea elegante. Con base de aluminio a 5 radios, ruedas engomadas, mecanismo knee-tilt o estructura cantilever para la silla confidente. Los brazos son en acero y acolchados.

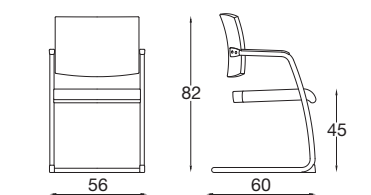



## Yoga

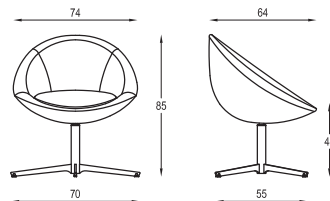

Poltrona da attesa, con struttura interna in acciaio e imbottita in schiumato a freddo, girevole, telaio cromato a 4 razze.

Armchair with internal structure in steel and padded with injected foam, on swivel 4 chromed blades frame.

Fauteuil, pour salles d'attente. La structure est en acier avec rembourrage écumé à froid. Piédiment de 4 rais en acier chromé tournant.

Butaca con estructura de acero y acolchada de poliuretano espumado a frío. Base a 4 radios en acero, giratoria.

## Xl - Xs

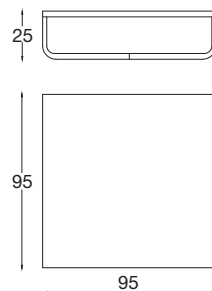

Tavolo da attesa, cm 95x95 con struttura in tubo metallico verniciato, altezza cm 25, ripiano in HPL bianco o nero oppure in melaminico noce canaletto.

Table for waiting areas, 95x95 cm, 25 cm height, with tubular chromed structure white or black painted, top in HPL white or black or walnut melamine finish.

Plan en HPL 95x95 cm blanc o noir au melamine noix et structure en métal laqué blanc o noir. Hauteur: 25 cm

Mesa de espera, llano de HPL 95x95 cm barnizado blanco o negro o de melamine nuez, 25 cm de altura y estructura en metal barnizado blanco o negro.

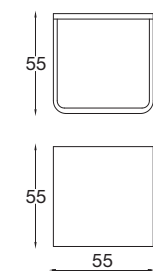

Tavolo da attesa, cm 55x55 con struttura in tubo metallico verniciato, altezza cm 55, ripiano in HPL bianco o nero oppure in melaminico noce canaletto.

Table for waiting areas, 55x55 cm, 55 cm height, with tubular chromed structure white or black painted, top in HPL, white or black painted or walnut melamine finish.

Plan en HPL 55x55 cm noir, ou blanc ou o noix melamine et structure en métal laqué blanc o noir. Hauteur: 55 cm

Mesa de espera, llano de HPL 55x55 cm barnizado blanco o negro o de melamine nuez, 55 cm de altura y estructura en metal barnizado blanco o negro.

## Zeta

Sedia ideale per la collettività, con o senza braccioli o con braccioli e tavoletta. Telaio 4 gambe verniciato grigio. Sedile imbottito e rivestito e schienale in polipropilene nero. Sedile ribaltabile, possibilità di impilare la sedia orizzontalmente.

Conference chair, with or without arms or with arms and tablet. 4 legs frame, aluminium color painted. Seat padded in polyurethane foam and upholstered. Foldable seat, stackable in an horizontal way.

Chaise de conférence, avec ou sin accoudoir, ou avec accoudoir et tablette écriteire. Séance rembourré et dossier en polypropylène noir. Seance pliant et la chaise est empilable horizontalement.

Silla para la comunidad y la espera, con o sin brazos o con brazos y mesa escritorio. Asiento acolchado y tapizado y respaldo en polipropileno negro. Asiento plegable y silla apilable horizontalmente.

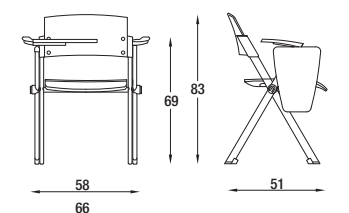
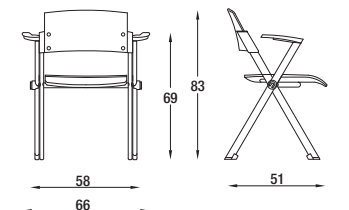
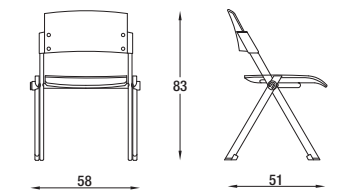

**A.D. Progetto Grafico:** Beatrice Carollo

**Fotografie:** Gianni Sabbadin

**Stampa:** Grafiche Duegi

**Gennaio 2018**



**DIEMME S.r.l.**

**Sede legale e operativa:** Via del Lavoro, 25 - Loc. Cimavilla -31013 Codognè (TV) Italy

Tel. +39 0438 778211 - Fax +39 0438 479836 - [www.diemmeoffice.com](http://www.diemmeoffice.com) - e-mail: [dm@diemmeoffice.com](mailto:dm@diemmeoffice.com)